

A Unified Approach to Multiterminal Source Coding

Richard Blahut and Soumya Jana

Department of Electrical and Computer engineering
University of Illinois, Urbana, IL 61801

October 23, 2006

Mathematical Theory of Source Coding

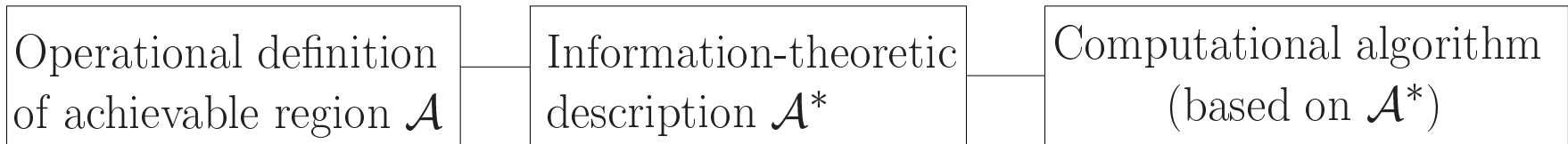

Example: *Shannon's rate-distortion problem*

\mathcal{A} based on ϵ -achievability
(\mathcal{A} convex)

\mathcal{A}^* based on mutual information
(envelope: rate-distortion function)

Blahut algorithm based on alternating projection onto convex sets

We give a unified formula \mathcal{A}^* ($= \mathcal{A}$) for source coding problems.

Generic Multiterminal Source Coding Problem

Consider $(X_1, \dots, X_M, W_1, \dots, W_K, S) \sim p$ and draw i.i.d. copies.

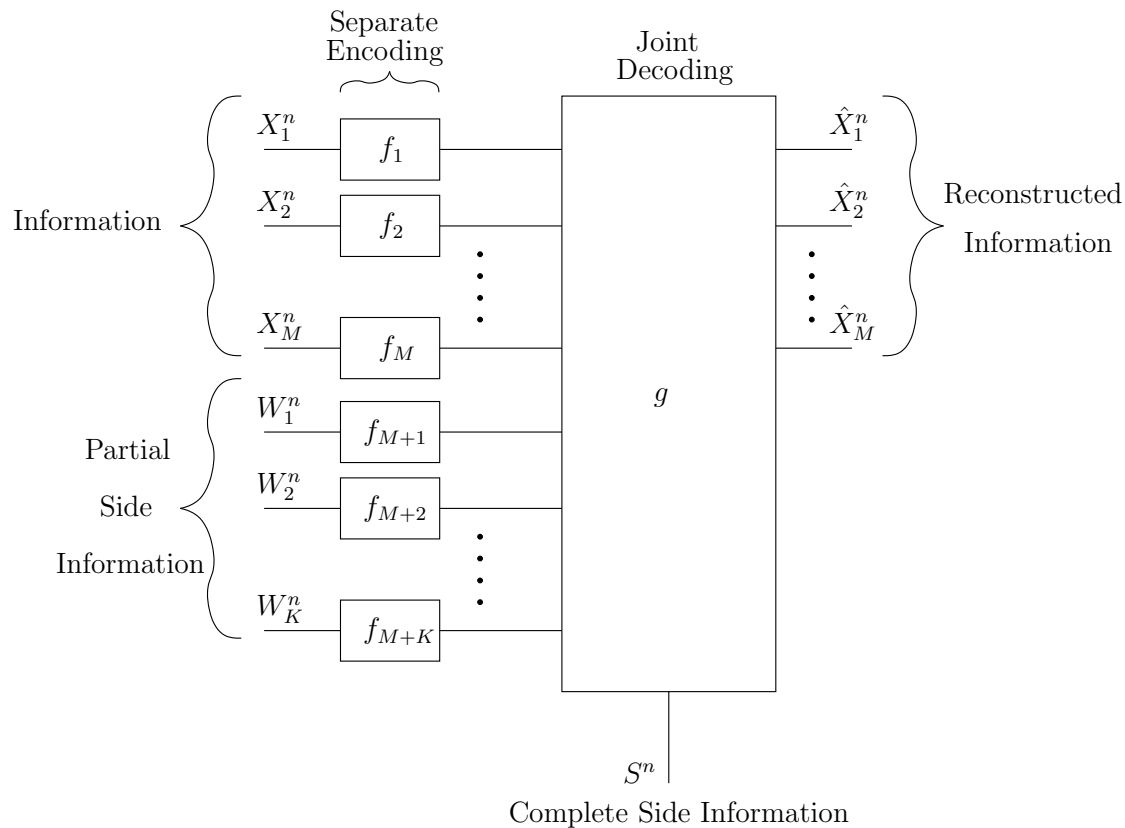

- Lossless reconstruction in $\{1, 2, \dots, J\}$
- L metrics on $\{J + 1, J + 2, \dots, M\}$
- Problem parameters: M, K, J, L , presence/absence of S .

Relation among Multiterminal Problems

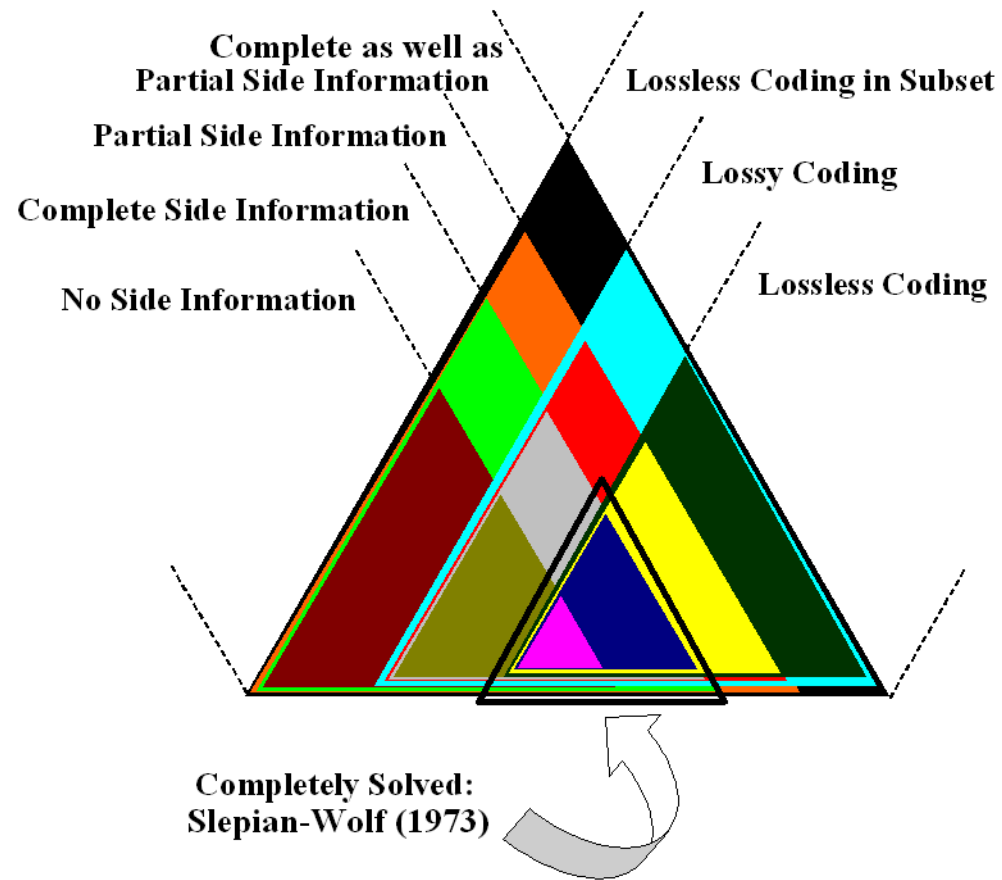

Special Case: Slepian-Wolf Problem

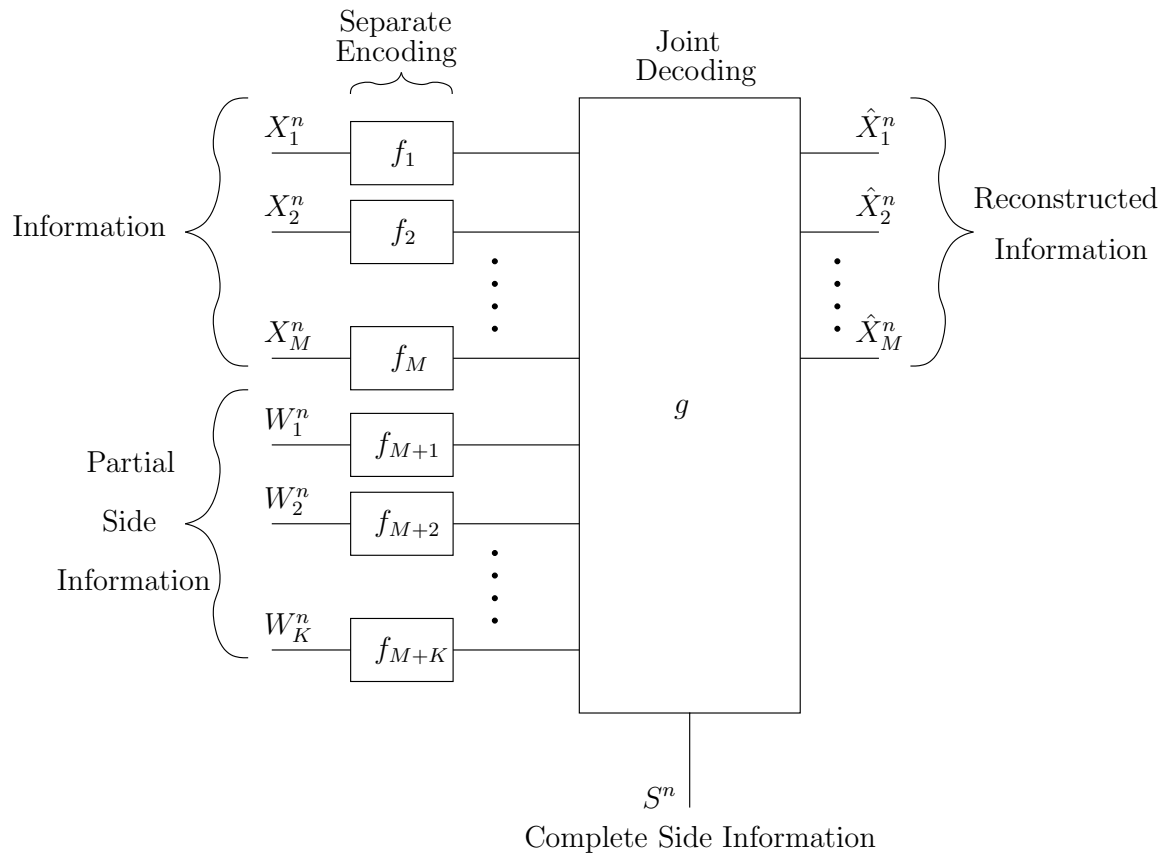

- M arbitrary
- $K = 0$
- $J = M$
- S absent/present

Slepian-Wolf Region: $M = 3$

$$H(X_1|X_2, X_3) \leq R_1$$

$$H(X_2|X_1, X_3) \leq R_2$$

$$H(X_1, X_2|X_3) \leq R_1 + R_2$$

$$H(X_3|X_1, X_2) \leq R_3$$

$$H(X_1, X_3|X_2) \leq R_1 + R_3$$

$$H(X_2, X_3|X_1) \leq R_2 + R_3$$

$$H(X_1, X_2, X_3) \leq R_1 + R_2 + R_3$$

General Setup: Salient Features of Unified Formula \mathcal{A}^*

- **Generic form** $\mathcal{A}^* = \overline{\bigcup_{n=1}^{\infty} \mathcal{A}_n^*}$:
 - Formula \mathcal{A}_n^* contains information-theoretic quantities involving n -tuple $(X_1^n, \dots, X_M^n, W_1^n, \dots, W_K^n, S^n)$ and auxiliary random variables.
- **Convexity:**
 - Individual \mathcal{A}_n^* not necessarily convex;
 - \mathcal{A}^* always convex (since $\mathcal{A}^* = \mathcal{A}$).
- **In all (previously) solved special cases** (e.g., Wyner-Ziv problem),
 - \mathcal{A}_1^* convex;
 - $\mathcal{A}_n^* = \mathcal{A}_1^*$ for each n ;
 - $\mathcal{A}^* = \mathcal{A}_1^*$; coincides with known expression.

Expression for \mathcal{A}_n^* for $M = 2, K = 2, J = 0, L = 1$

Set of (R_1, R_2, R_3, R_4, D) : $\exists q_1(z_1|x_1^n), q_2(z_2|x_2^n), q_3(z_3|w_1^n), q_4(z_4|w_4^n), \psi$

$$(X_1^n, X_2^n, W_1^n, W_2^n, S^n, Z_1, Z_2, Z_3, Z_4)$$

$$\sim \prod_{k=1}^n p(x_1(k), x_2(k), w_1(k), w_2(k), s(k))$$

$$q_1(z_1|x_1^n)q_2(z_2|x_2^n)q_3(z_3|w_1^n)q_4(z_4|w_2^n)$$

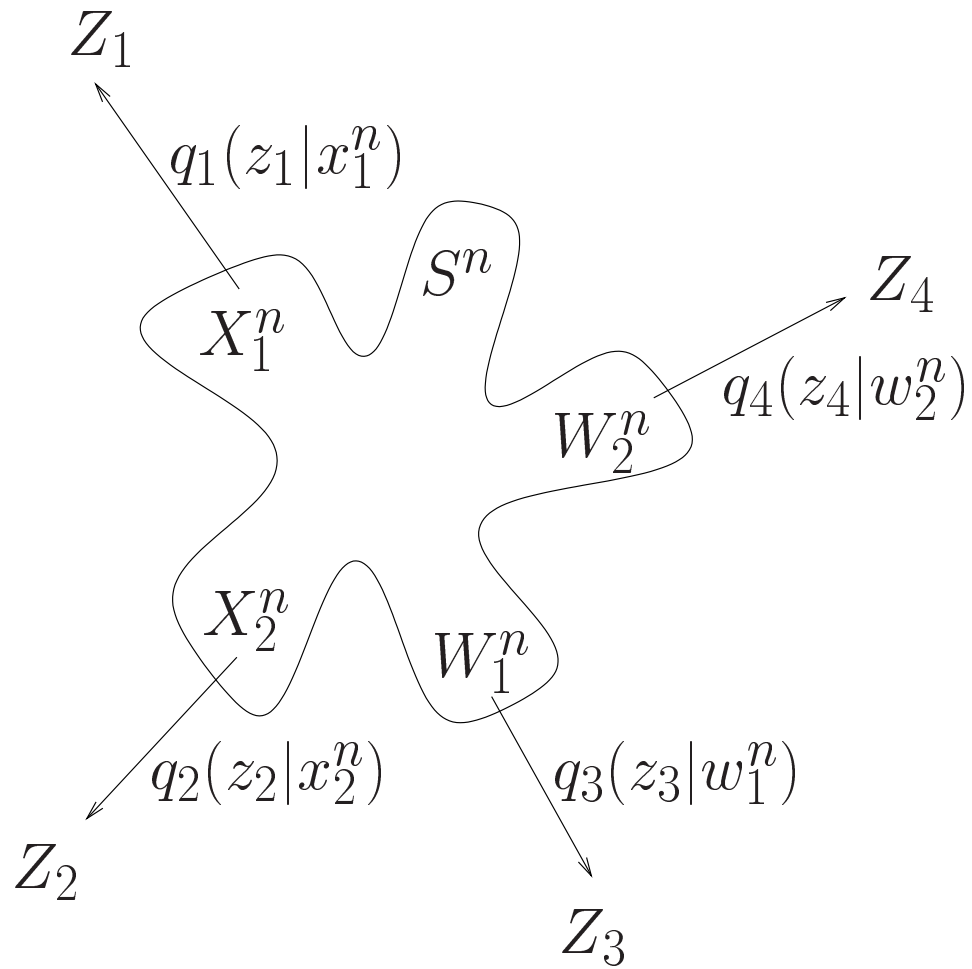

$$\frac{1}{n}I(X_1^n; Z_1|Z_2, Z_3, Z_4, S^n) \leq R_1 \quad (1)$$

$$\frac{1}{n}I(X_2^n; Z_2|Z_1, Z_3, Z_4, S^n) \leq R_2 \quad (2)$$

$$\frac{1}{n}I(X_1^n, X_2^n; Z_1, Z_2|Z_3, Z_4, S^n) \leq R_1 + R_2 \quad (3)$$

$$\frac{1}{n}I(W_1^n; Z_3|Z_1, Z_2, Z_4, S^n) \leq R_3 \quad (4)$$

$$\frac{1}{n}I(W_2^n; Z_4|Z_1, Z_2, Z_3, S^n) \leq R_4 \quad (5)$$

$$\frac{1}{n}I(W_1^n, W_2^n; Z_3, Z_4|Z_1, Z_2, S^n) \leq R_3 + R_4 \quad (6)$$

$$\frac{1}{n}\mathbb{E}d_n((X_1^n, X_2^n), \psi(Z_1, Z_2, Z_3, Z_4, S^n)) \leq D \quad (7)$$

Expression for \mathcal{A}_n^* for $M = 2, K = 2, J = 1, L = 1$

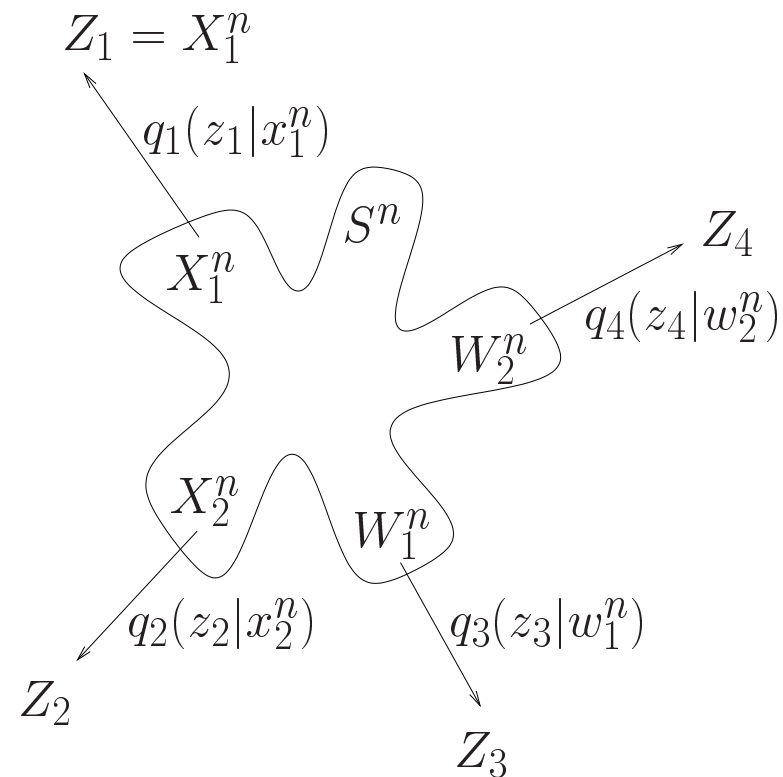

Expression for \mathcal{A}_n^* for $M = 2, K = 2, J = 2$

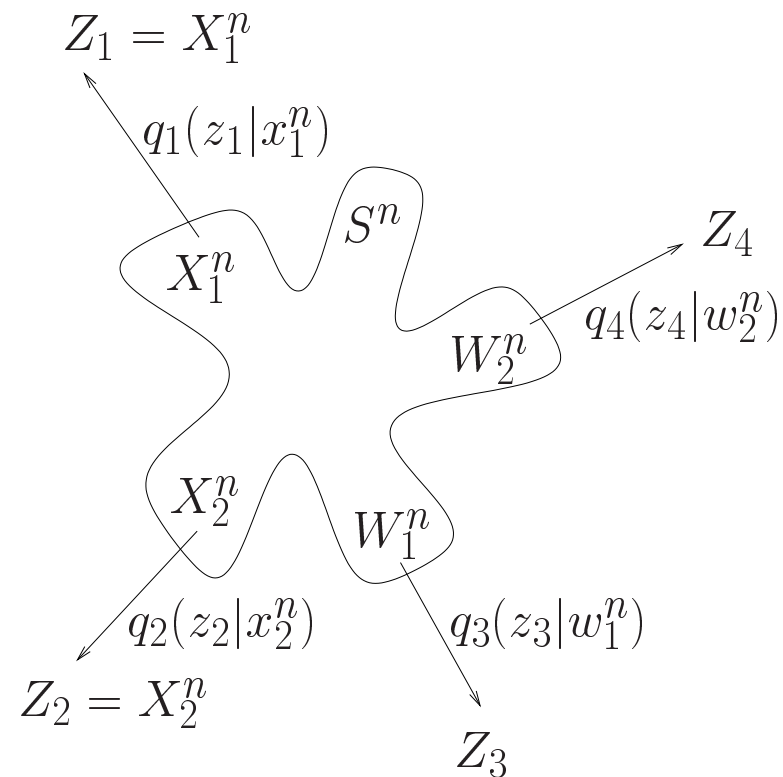

$$\frac{1}{n}H(X_1^n|X_2^n, Z_3, Z_4, S^n) \leq R_1$$

$$\frac{1}{n}H(X_2^n|X_1^n, Z_3, Z_4, S^n) \leq R_2$$

$$\frac{1}{n}H(X_1^n, X_2^n|Z_3, Z_4, S^n) \leq R_1 + R_2$$

$$\frac{1}{n}I(W_1^n; Z_3|X_1^n, X_2^n, Z_4, S^n) \leq R_3$$

$$\frac{1}{n}I(W_2^n; Z_4|X_1^n, X_2^n, Z_3, S^n) \leq R_4$$

$$\frac{1}{n}I(W_1^n, W_2^n; Z_3, Z_4|X_1^n, X_2^n, S^n) \leq R_3 + R_4$$

Steps in Showing $\mathcal{A} = \mathcal{A}^*$

Proof of inner bound $\mathcal{A} \supseteq \mathcal{A}^*$:

- (*Distortion dissociation: key to unified theory*) Derivation of distortion-independent coding principle;
- Incorporation of distortion metric, when applicable.

Proof of outer bound $\mathcal{A} \subseteq \mathcal{A}^*$:

- Applying simple information-theoretic inequalities;
- Limiting set-theoretic argument.

References

1. S. Jana, “Unified Structural View of Multiterminal Source Coding,” Ph.D. dissertation, University of Illinois, Urbana, IL, 2005.
2. S. Jana, “Unified Theory of Source Coding: Part I – Two-Terminal Problems,” submitted to *IEEE Trans. on Inform. Theory*. Available from

http://arxiv.org/PS_cache/cs/pdf/0508/0508118.pdf.
3. S. Jana, “Unified Theory of Source Coding: Part II – Multiterminal Problems,” submitted to *IEEE Trans. on Inform. Theory*. Available from

http://arxiv.org/PS_cache/cs/pdf/0508/0508119.pdf.

Outline of Remaining Presentation

- Overview: One- and two-terminal problems, both solved and open
- Consistency of unified formula: Partial side information (open) problem
- **Distortion dissociation** principle
 - Shannon's rate-distortion problem (*generalization of Berger's lemma*)
 - Wyner-Ziv problem
 - Joint distortion (open) problem
- Derivation of unified solution for joint distortion problem
- On sufficiency of first-order description, etc.

One- and Two-Terminal Problems: Completely Solved

- Shannon's lossless coding problem (1948): $M = 1, K = 0, J = 1$, no S .
- Shannon's rate-distortion problem (1959): $M = 1, K = 0, J = 0, L = 1$, no S .
- Slepian-Wolf problem (1973): $M = 2, K = 0, J = 2$, no S .
- Wyner-Ahlsvede-Körner problem (1975): $M = 1, K = 1, J = 1$, no S .
- Wyner-Ziv problem (1976): $M = 1, K = 0, J = 0, L = 1$, S : yes.
- Berger-Yeung problem (1989): $M = 2, K = 0, J = 1, L = 1$, no S .

One- and Two-Terminal Problems: Hitherto Open

- Partial side information problem: $M = 1, K = 1, J = 0, L = 1$, no S .
 - Inner bound by Berger *et al.* (1979)
- Joint distortion problem: $M = 2, K = 0, J = 0, L = 1$, no S .
 - Inner bound for separable distortion metric by Berger-Tung (1977)

Shannon's Lossless and Lossy Coding Problems

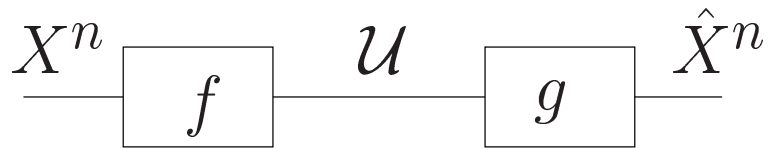

$$\frac{1}{n} \log |\mathcal{U}| \leq R + \epsilon$$

Lossless Coding (1948)

$$\Pr\{X^n \neq \hat{X}^n\} \leq \epsilon$$

$$H(X) \leq R$$

Lossy Coding (1959)

$$\frac{1}{n} \mathbb{E} d_n(X^n, \hat{X}^n) \leq D + \epsilon$$

$$\begin{aligned} I(X; Z) &\leq R \\ \mathbb{E} d(X, Z) &\leq D \end{aligned}$$

Coding with Complete Side Information

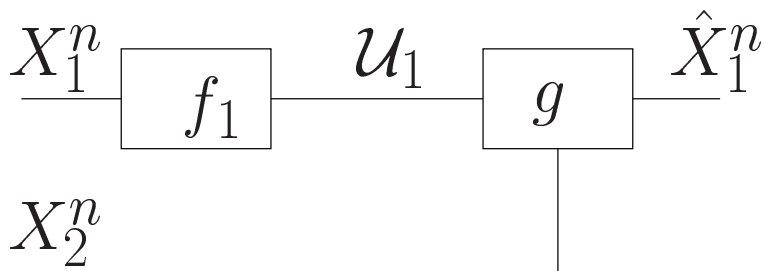

$$\frac{1}{n} \log |\mathcal{U}_1| \leq R_1 + \epsilon$$

Lossless Coding: Corollary of Slepian-Wolf theory (1973)

$$\Pr\{X_1^n \neq \hat{X}_1^n\} \leq \epsilon \quad H(X_1|X_2) \leq R_1$$

Lossy coding: Wyner-Ziv (1976)

$$\frac{1}{n} \mathbf{E} d_n(X_1^n, \hat{X}_1^n) \leq D + \epsilon \quad \min_{\psi} \mathbf{E} d(X_1, \psi(Z_1, X_2)) \leq D$$

$$(X_2 \rightarrow X_1 \rightarrow Z_1) \quad I(X_1; Z_1|X_2) \leq R$$

Coding with Partial Side Information

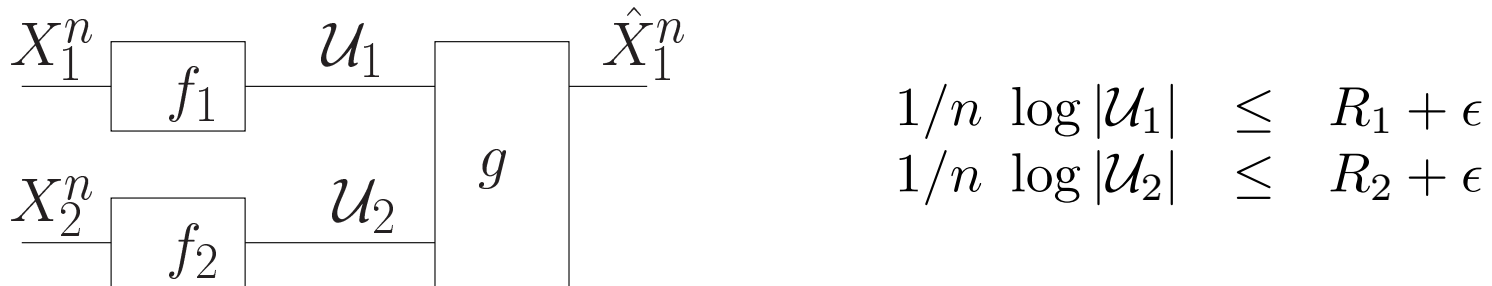

Lossless Coding: Wyner-Ahlsvede-Körner (1975)

$$\Pr\{X_1^n \neq \hat{X}_1^n\} \leq \epsilon$$

$$\begin{aligned} H(X_1|Z_2) &\leq R_1 \\ I(X_2; Z_2) &\leq R_2 \\ (X_1 \rightarrow X_2 \rightarrow Z_2) \end{aligned}$$

Coding with Partial Side Information (Continued)

Lossless Coding: Wyner-Ahlsvede-Körner (1975)

$$\Pr\{X_1^n \neq \hat{X}_1^n\} \leq \epsilon \quad \begin{array}{l} H(X_1|Z_2) \leq R_1 \\ I(X_2; Z_2) \leq R_2 \\ (X_1 \rightarrow X_2 \rightarrow Z_2) \end{array}$$

Lossy coding: Inner bound by Berger et al. (1979)

$$\frac{1}{n} \mathbf{E} d_n(X_1^n, \hat{X}_1^n) \leq D + \epsilon \quad \begin{array}{l} I(X_1; Z_1|Z_2) \leq R_1 \\ I(X_2; Z_2) \leq R_2 \\ \min_{\psi} \mathbf{E} d(X_1, \psi(Z_1, Z_2)) \leq D \\ (Z_2 \rightarrow X_2 \rightarrow X_1 \rightarrow Z_1) \end{array}$$

Reconstruction of Both Sources

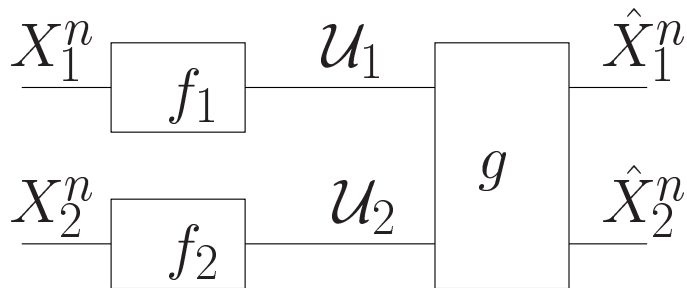

$$1/n \log |\mathcal{U}_1| \leq R_1 + \epsilon$$

$$1/n \log |\mathcal{U}_2| \leq R_2 + \epsilon$$

Lossless Coding: Slepian-Wolf (1973)

$$\Pr\{(X_1^n, X_2^n) \neq (\hat{X}_1^n, \hat{X}_2^n)\} \leq \epsilon$$

$$H(X_1|X_2) \leq R_1$$

$$H(X_2|X_1) \leq R_2$$

$$H(X_1, X_2) \leq R_1 + R_2$$

Mixed Lossless-Lossy Coding: Berger-Yeung (1989)

$$\begin{array}{rcl}
 \Pr\{X_1^n \neq \hat{X}_1^n\} & \leq & \epsilon \\
 \frac{1}{n} \mathbf{E}d_n(X_2^n, \hat{X}_2^n) & \leq & D + \epsilon \\
 \end{array}
 \quad
 \begin{array}{rcl}
 H(X_1|Z_2) & \leq & R_1 \\
 I(X_2; Z_2|X_1) & \leq & R_2 \\
 H(X_1) + I(X_2; Z_2|X_1) & \leq & R_1 + R_2 \\
 \min_{\psi} \mathbf{E}d(X_2, \psi(X_1, Z_2)) & \leq & D \\
 (X_1 \rightarrow X_2 \rightarrow Z_2) & &
 \end{array}$$

Lossy coding with separable distortion metric: Inner bound by Berger-Tung (1977)

$$\begin{array}{rcl}
 \Pr\{X_1^n \neq \hat{X}_1^n\} & \leq & \epsilon \\
 \frac{1}{n} \mathbf{E}d_{1n}(X_1^n, \hat{X}_1^n) & \leq & D_1 + \epsilon \\
 \frac{1}{n} \mathbf{E}d_{2n}(X_2^n, \hat{X}_2^n) & \leq & D_2 + \epsilon \\
 \end{array}
 \quad
 \begin{array}{rcl}
 I(X_1; Z_1|Z_2) & \leq & R_1 \\
 I(X_2; Z_2|Z_1) & \leq & R_2 \\
 I(X_1, X_2; Z_1, Z_2) & \leq & R_1 + R_2 \\
 \min_{\psi_1} \mathbf{E}d_1(X_1, \psi_1(Z_1, Z_2)) & \leq & D_1 \\
 \min_{\psi_2} \mathbf{E}d_2(X_2, \psi_2(Z_1, Z_2)) & \leq & D_2 \\
 (Z_1 \rightarrow X_1 \rightarrow X_2 \rightarrow Z_2) & &
 \end{array}$$

Complete Solution: Partial Side Information

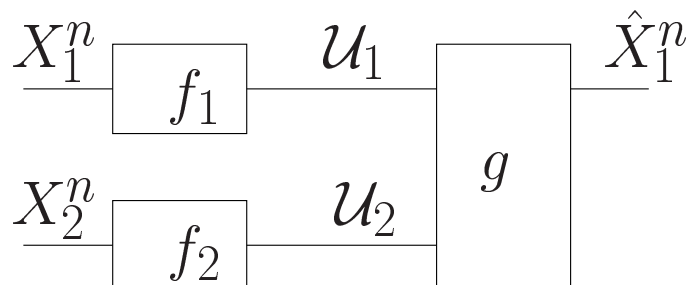

$$\begin{aligned} 1/n \log |\mathcal{U}_1| &\leq R_1 + \epsilon \\ 1/n \log |\mathcal{U}_2| &\leq R_2 + \epsilon \\ 1/n \mathbb{E} d_n(X_1^n, \hat{X}_1^n) &\leq D + \epsilon \end{aligned}$$

$$\mathcal{A}^* = \overline{\bigcup_{n=1}^{\infty} \mathcal{A}_n^*} \quad \text{with } \mathcal{A}_n^*:$$

$$\begin{aligned} 1/n I(X_1^n; Z_1 | Z_2) &\leq R_1 \\ 1/n I(X_2^n; Z_2) &\leq R_2 \\ \min_{\psi} 1/n \mathbb{E} d_n(X_1^n, \psi(Z_1, Z_2)) &\leq D \\ &(Z_2 \rightarrow X_2 \rightarrow X_1 \rightarrow Z_1) \end{aligned}$$

Consistency with Known Special Cases

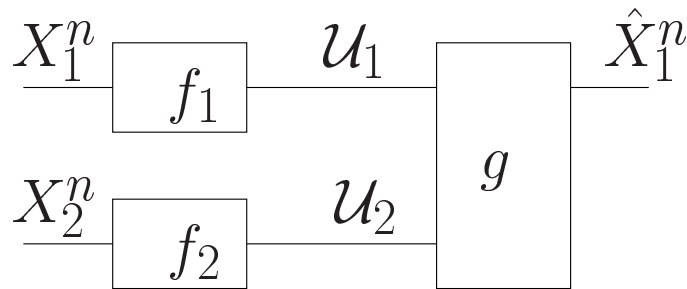

$$\begin{aligned} 1/n \log |\mathcal{U}_1| &\leq R_1 + \epsilon \\ 1/n \log |\mathcal{U}_2| &\leq R_2 + \epsilon \\ 1/n \mathbb{E} d_n(X_1^n, \hat{X}_1^n) &\leq D + \epsilon \end{aligned}$$

- Shannon's R-D theory: $R_2 = 0$
- Wyner-Ahlsvede-Körner theory: $D = 0$
- Wyner-Ziv theory: $R_2 = H(X_2)$
- Rate-constrained estimation: $R_1 = 0$

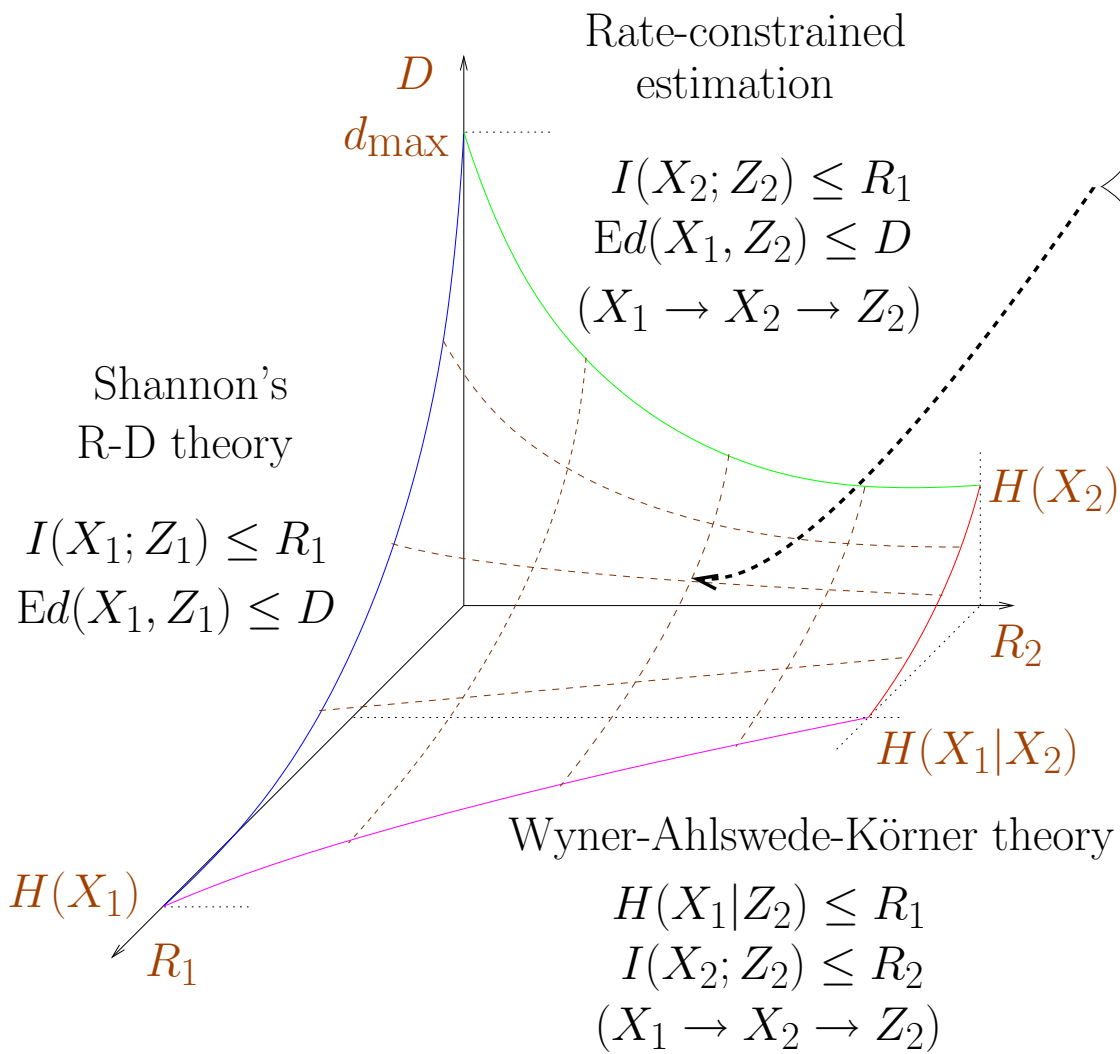

$$\mathcal{A}_n^*$$

$$\frac{1}{n}I(X_1^n; Z_1|Z_2) \leq R_1$$

$$\frac{1}{n}I(X_2^n; Z_2) \leq R_2$$

$$\frac{1}{n}Ed_n(X_1^n, \psi(Z_1, Z_2)) \leq D$$

$$(Z_1 \rightarrow X_1^n \rightarrow X_2^n \rightarrow Z_2)$$

Wyner-Ziv theory

$$I(X_1; Z_1|X_2) \leq R_1$$

$$Ed(X_1, \psi(Z_1, X_2)) \leq D$$

$$(Z_1 \rightarrow X_1 \rightarrow X_2)$$

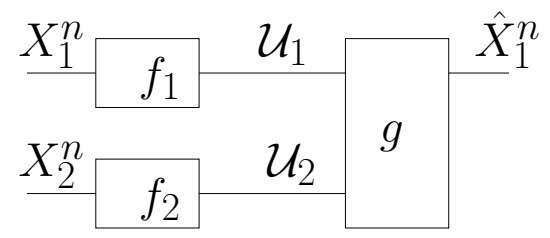

Complete Solution: Joint Distortion Problem

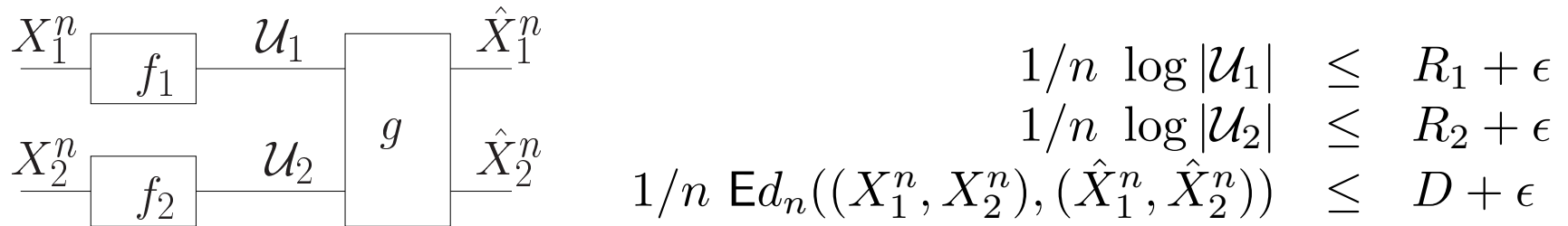

$$\mathcal{A}^* = \overline{\bigcup_{n=1}^{\infty} \mathcal{A}_n^*} \quad \text{with } \mathcal{A}_n^*:$$

$$1/n I(X_1^n; Z_1 | Z_2) \leq R_1$$

$$1/n I(X_2^n; Z_2 | Z_1) \leq R_2$$

$$1/n I(X_1^n, X_2^n; Z_1, Z_2) \leq R_1 + R_2$$

$$\min_{\psi} 1/n \mathbf{E} d_n((X_1^n, X_2^n), \psi(Z_1, Z_2)) \leq D$$

$$(Z_2 \rightarrow X_2 \rightarrow X_1 \rightarrow Z_1)$$

Relation among One- and Two-Terminal Problems

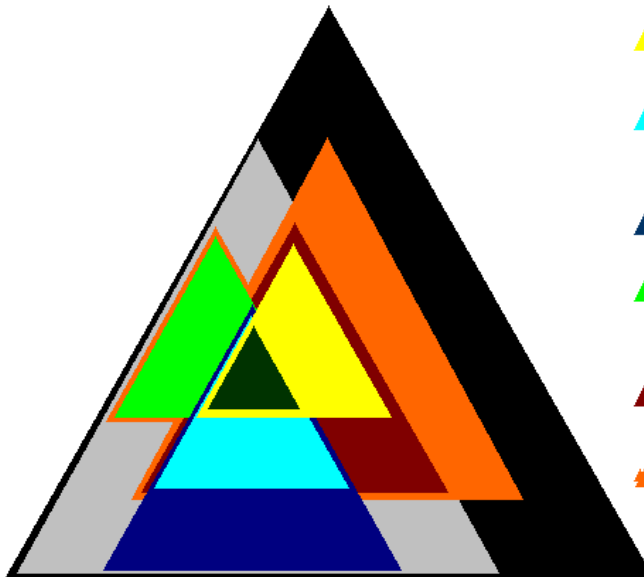

- ▲ **Shannon's Lossless Coding (1948)**
- ▲ **Shannon's Lossy Coding (1959)**
- ▲ **Lossless Coding with Complete Side Information: Slepian-Wolf (1973)**
- ▲ **General Slepian-Wolf Problem (1973)**
- ▲ **Lossless Coding with Partial Side Information: Wyner/Ahlsvede-Korner (1975)**
- ▲ **Wyner-Ziv Problem (1976)**
- ▲ **Partial Side Information Problem: Inner Bound on achievable region by Berger *et. al* (1979); Complete solution hitherto unknown**
- ▲ **Berger-Yeung Problem (1989)**
- ▲ **Joint Distortion Problem: Hitherto unsolved [Inner bound for separable distortion metric by Berger-Tung (1977)]**

Distortion Dissociation Principle: Key to Unification

Distortion-independent problem:

- Depends on structure
- Based on strong typicality

Shannon problem

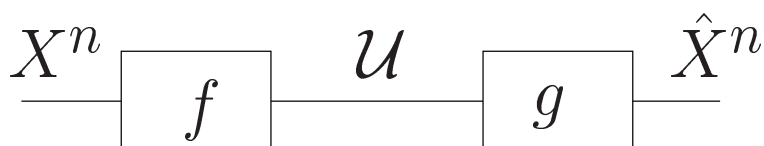

$$1/n \log |\mathcal{U}| \leq R + \epsilon$$

$$1/n \mathbf{E}d_n(X^n, \hat{X}^n) \leq D + \epsilon$$

Step 1:

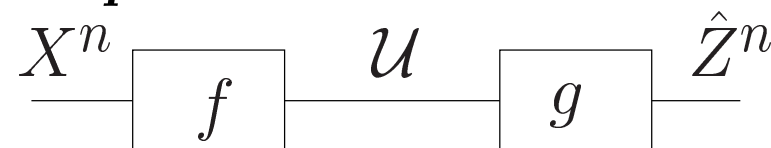

$$1/n \log |\mathcal{U}| \leq R + \epsilon$$

$$\Pr\{(X^n, \hat{Z}^n) \notin \mathcal{T}_\epsilon^{(n)}(X, Z)\} \leq \epsilon$$

Step 2:

Choose $q(z|x)$: $\mathbf{E}d(X, Z) \leq D$.

Then

$$1/n \mathbf{E}d_n(X^n, \hat{Z}^n) \leq D + \epsilon d_{\max}.$$

Set $\hat{X}^n = \hat{Z}^n$.

Wyner-Ziv problem

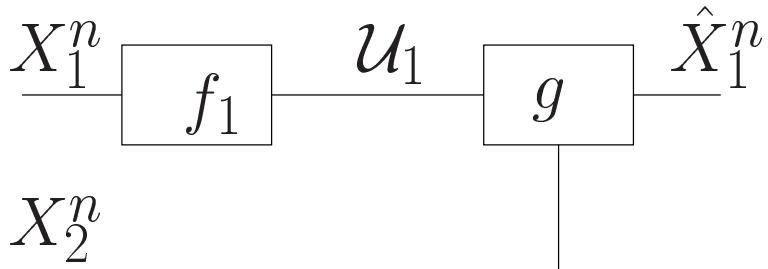

$$1/n \log |\mathcal{U}_1| \leq R_1 + \epsilon$$

$$1/n \mathbf{E}d_n(X_1^n, \hat{X}_1^n) \leq D + \epsilon$$

Step 1: ($X_2 \rightarrow X_1 \rightarrow Z_1$)

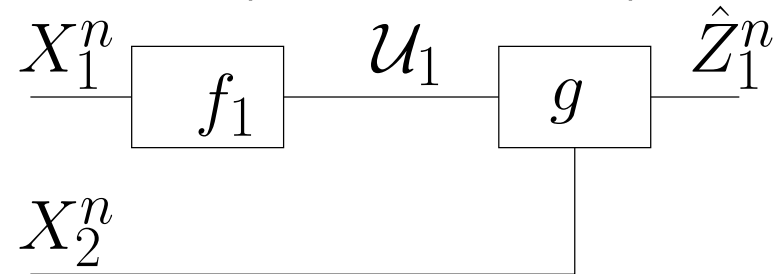

$$1/n \log |\mathcal{U}_1| \leq R_1 + \epsilon$$

$$\Pr\{(X_1^n, X_2^n, \hat{Z}_1^n) \notin \mathcal{T}_\epsilon^{(n)}(X_1, X_2, Z_1)\} \leq \epsilon$$

Step 2:

Choose $q_1(z_1|x_1)$:

$\mathbf{E}d(X_1, \psi(Z_1, X_2)) \leq D$. Then

$1/n \mathbf{E}d_n(X_1^n, \psi_n(\hat{Z}_1^n, X_2^n)) \leq D + \epsilon d_{\max}$.

Set $\hat{X}_1^n = \psi_n(\hat{Z}_1^n, X_2^n)$.

Joint distortion problem

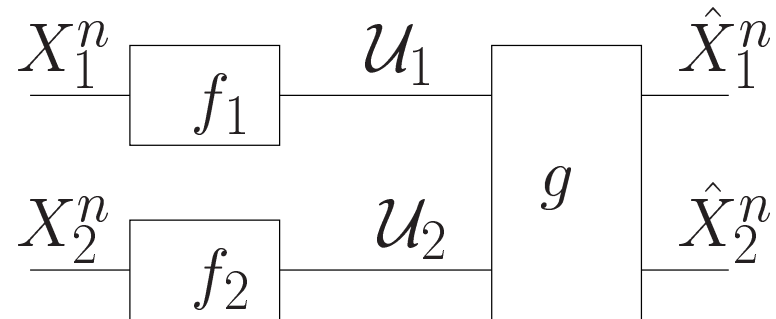

$$1/n \log |\mathcal{U}_1| \leq R_1 + \epsilon$$

$$1/n \log |\mathcal{U}_2| \leq R_2 + \epsilon$$

$$1/n \mathbf{E}d_n((X_1^n, X_2^n), (\hat{X}_1^n, \hat{X}_2^n)) \leq D + \epsilon$$

Step 1: ($Z_2 \rightarrow X_2 \rightarrow X_1 \rightarrow Z_1$)

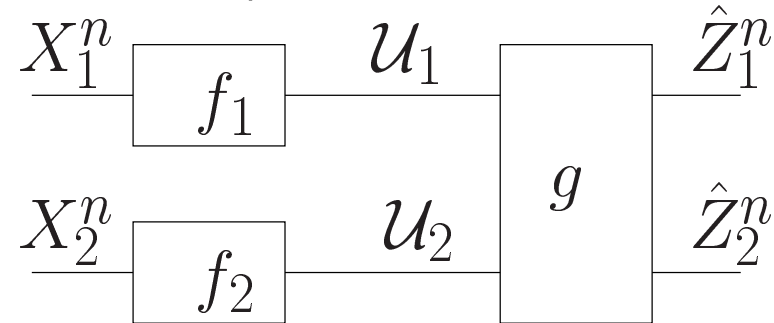

$$1/n \log |\mathcal{U}_1| \leq R_1 + \epsilon$$

$$1/n \log |\mathcal{U}_2| \leq R_2 + \epsilon$$

$$\Pr\{(X_1^n, X_2^n, \hat{Z}_1^n, \hat{Z}_2^n) \notin \mathcal{T}_\epsilon^{(n)}(X_1, X_2, Z_1, Z_2)\} \leq \epsilon$$

Step 2:

Choose $q_1(z_1|x_1)$ and $q_2(z_2|x_2)$:

$\mathbf{E}d((X_1, X_2), \psi(Z_1, Z_2)) \leq D$. Then

$$1/n \mathbf{E}d_n((X_1^n, X_2^n), \psi_n(\hat{Z}_1^n, \hat{Z}_2^n)) \leq D + \epsilon d_{\max}.$$

Set $(\hat{X}_1^n, \hat{X}_2^n) = \psi_n(\hat{Z}_1^n, \hat{Z}_2^n)$.

Distortion-Independent Problems: Inner Bound on Achievable Rate-Region

- Shannon problem: $I(X; Z) \leq R$
- Wyner-Ziv problem: $I(X_1; Z_1|X_2) \leq R_1$
- Joint distortion problem:

$$I(X_1; Z_1|Z_2) \leq R_1$$

$$I(X_2; Z_2|Z_1) \leq R_2$$

$$I(X_1, X_2; Z_1, Z_2) \leq R_1 + R_2$$

Distortion-Independent Shannon Problem

- Inner bound: $I(X; Z) \leq R$
- Derivation:
 - Using strong typicality: Concise, little insight
 - Using method of types: Combinatorial insight (type covering), generalization of Berger's lemma

Our Type Covering Result

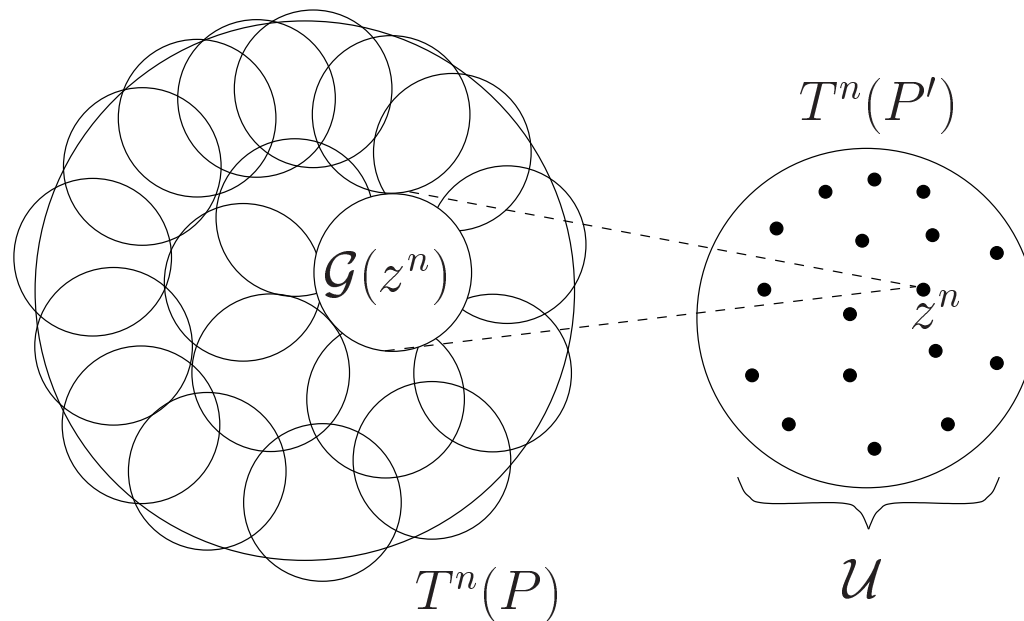

- $\bar{P}(x, z) = P(x)Q(z|x)$
and P' is Z -marginal.
- $\mathcal{G}(z^n) = \{x^n\}$: (x^n, z^n) of
joint type \bar{P} .
- $|\mathcal{G}(z^n)| \approx 2^{nH(X|Z)}$.
- $\frac{1}{n} \log |\mathcal{U}| \leq I(X; Z) + \epsilon$.
- $\mathcal{G}(z^n)$'s cover $T^n(P)$.

Distortion-Dependent Choice

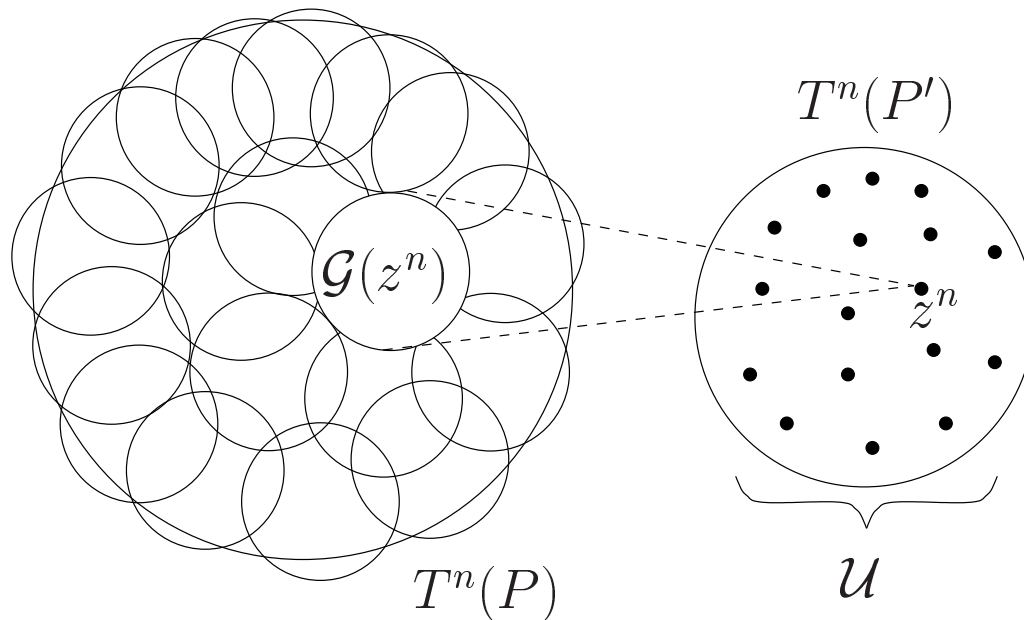

- For any $Q(z|x)$ such that $\mathbb{E} d(X, Z) \leq D$,

$$\frac{1}{n} d_n(x^n, z^n) \leq D,$$

$$\forall x^n \in \mathcal{G}(z^n), z^n \in \mathcal{U}.$$

- Required bit-rate

$$\inf_Q \frac{1}{n} \log |\mathcal{U}| \leq \inf_Q I(X; Z) + \epsilon.$$

Berger's Lemma as Corollary

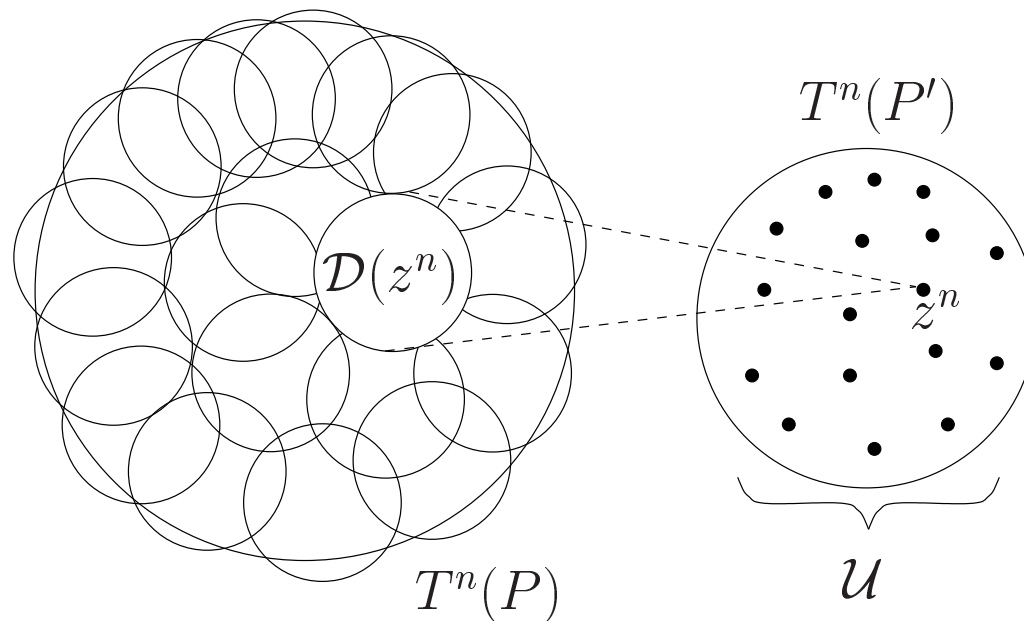

- $\mathcal{D}(z^n)$: D -ball around z^n .
- (Recall) $\mathcal{G}(z^n) \subseteq \mathcal{D}(z^n)$ for any D -admissible $Q(z|x)$.
- $\mathcal{D}(z^n)$'s cover $T^n(P)$.
- $\frac{1}{n} \log |\mathcal{U}| \leq \inf I(X; Z) + \epsilon$,
inf over admissible $Q(z|x)$'s.

Joint-Distortion Problem: Rate-Region in Distortion-Independent Version

- Inner bound:

$$I(X_1; Z_1|Z_2) \leq R_1$$

$$I(X_2; Z_2|Z_1) \leq R_2$$

$$I(X_1, X_2; Z_1, Z_2) \leq R_1 + R_2$$

- Derivation using distortion-independent
 - Shannon problem: $I(X; Z) \leq R$
 - Wyner-Ziv problem: $I(X_1; Z_1|X_2) \leq R_1$

Joint-Distortion Problem: Distortion-Independent Region

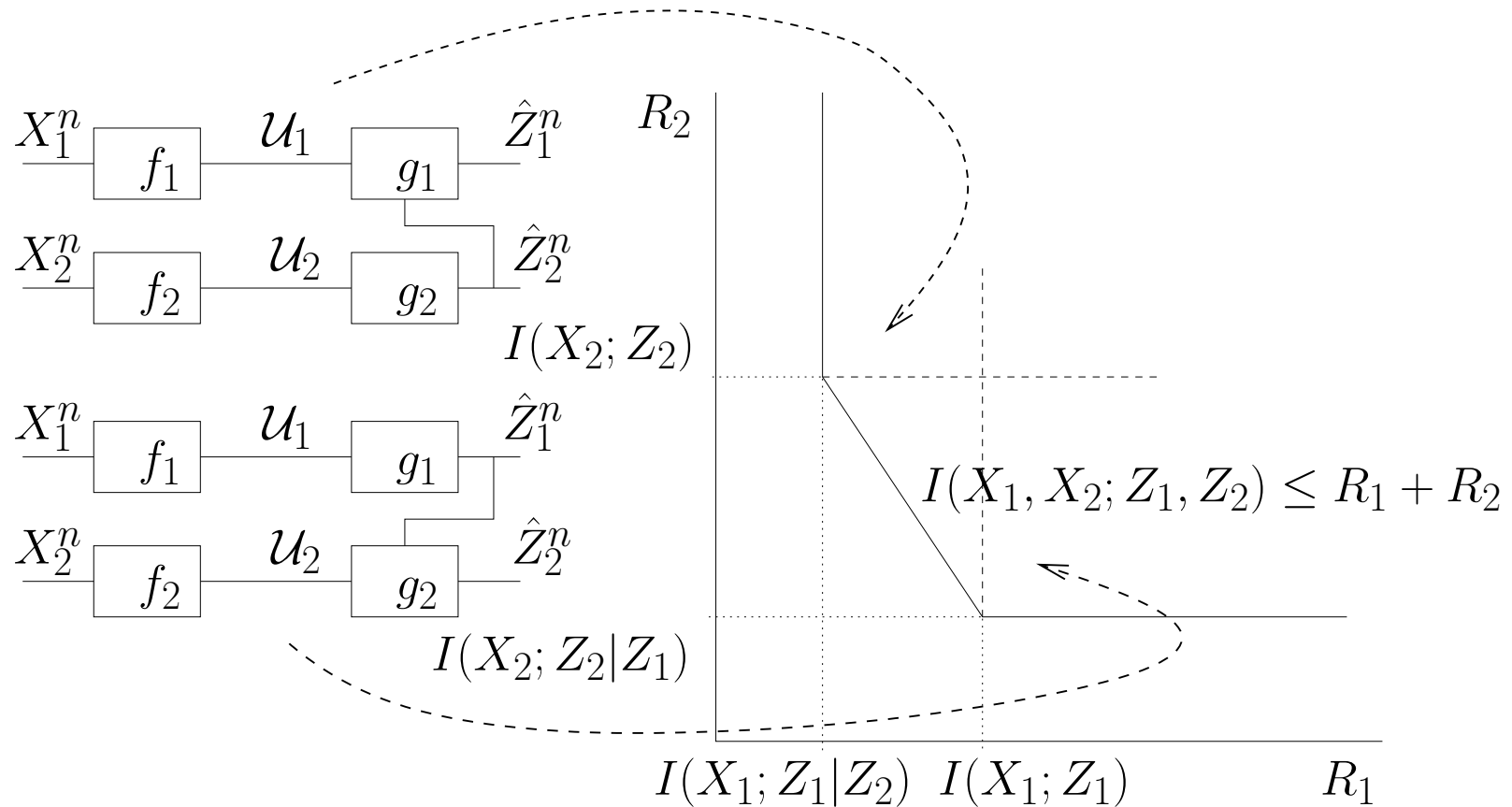

Proof of Inner Bound: $\mathcal{A} \supseteq \mathcal{A}^*$

- Incorporation of distortion: $\mathcal{A} \supseteq \mathcal{A}_1^*$
- n -tuple $\Rightarrow \mathcal{A} \supseteq \mathcal{A}_n^*$
- Taking union and closure:

$$\mathcal{A} \supseteq \overline{\bigcup_{n=1}^{\infty} \mathcal{A}_n^*} = \mathcal{A}^*.$$

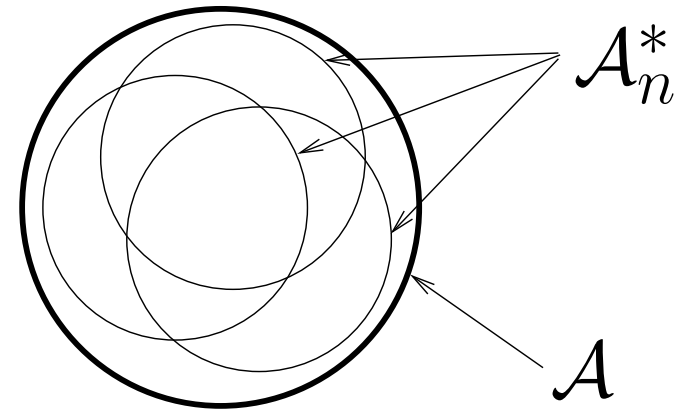

Proof of Outer Bound: $\mathcal{A} \subseteq \mathcal{A}^*$

$$(R_1, R_2, D) \in \mathcal{A}$$

\Rightarrow For any $\epsilon > 0$ and some $n(\epsilon)$,

$$(R_1 + \epsilon, R_2 + \epsilon, D + \epsilon) \in \mathcal{A}_n^*$$

(i.e., $(R_1, R_2, D) \in \mathcal{A}_n^{*(\epsilon)}$)

$$\Rightarrow (R_1, R_2, D) \in \mathcal{A}^{*(\epsilon)} = \overline{\bigcup_{n=1}^{\infty} \mathcal{A}_n^{*(\epsilon)}}$$

$$\Rightarrow (R_1, R_2, D) \in \mathcal{A}^* = \bigcap_{\epsilon > 0} \mathcal{A}^{*(\epsilon)}$$

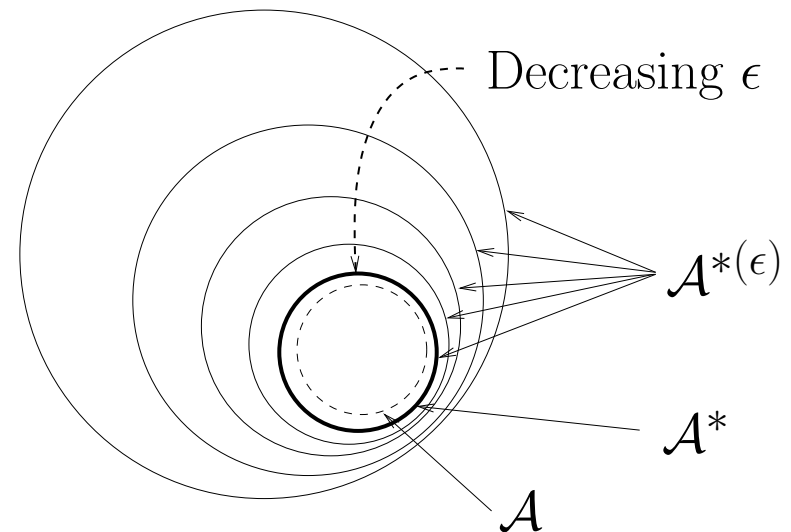

Representation by Convex Hulls of \mathcal{A}_n^*

- We know: $\mathcal{A} = \mathcal{A}^* = \overline{\bigcup_{n=1}^{\infty} \mathcal{A}_n^*}$ is convex.
- Define: $\mathcal{B}_n^* = \text{convex hull of } \mathcal{A}_n^*$; $\mathcal{B}^* = \overline{\bigcup_{n=1}^{\infty} \mathcal{B}_n^*}$.
- Then: $\mathcal{A} = \mathcal{B}^*$.

Necessary and Sufficient Condition: $\mathcal{A} = \mathcal{B}_1^*$

For each n and any $(R_1, R_2, D) \in \mathcal{A}_n^*$:

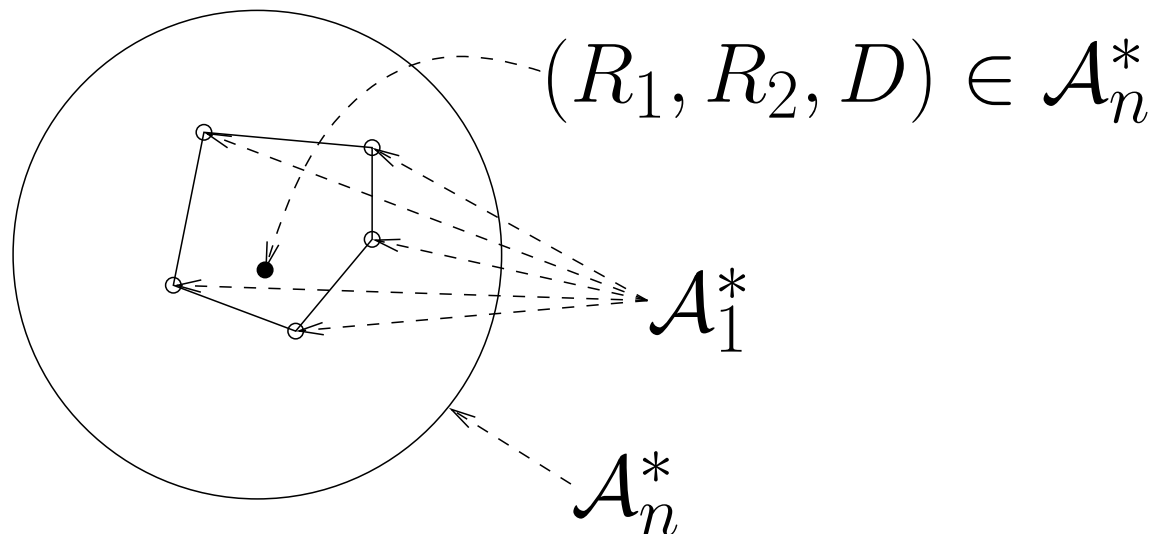

Necessary and Sufficient Condition: $\mathcal{A} = \mathcal{A}_1^*$

1. Condition for $\mathcal{A} = \mathcal{B}_1^*$:

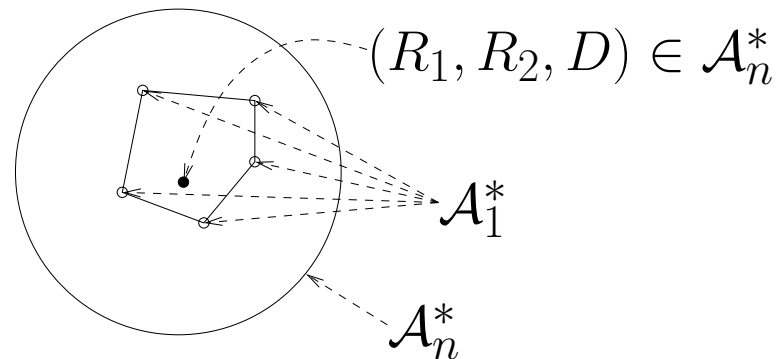

2. Convexity of \mathcal{A}_1^* .

Illustration of Nonconvexity of \mathcal{A}_1^*

Partial side information problem: $X_1 = X_2 = X \sim (1/2, 1/2)$

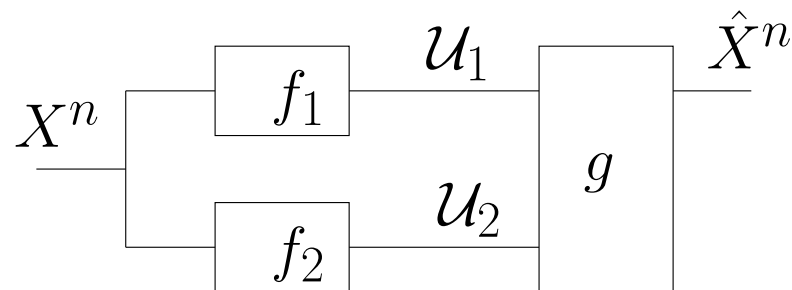

Rate-distortion region: $\mathcal{C} (= \mathcal{A})$

$$I(X; Z) \leq R_1 + R_2$$

$$Ed(X, Z) \leq D$$

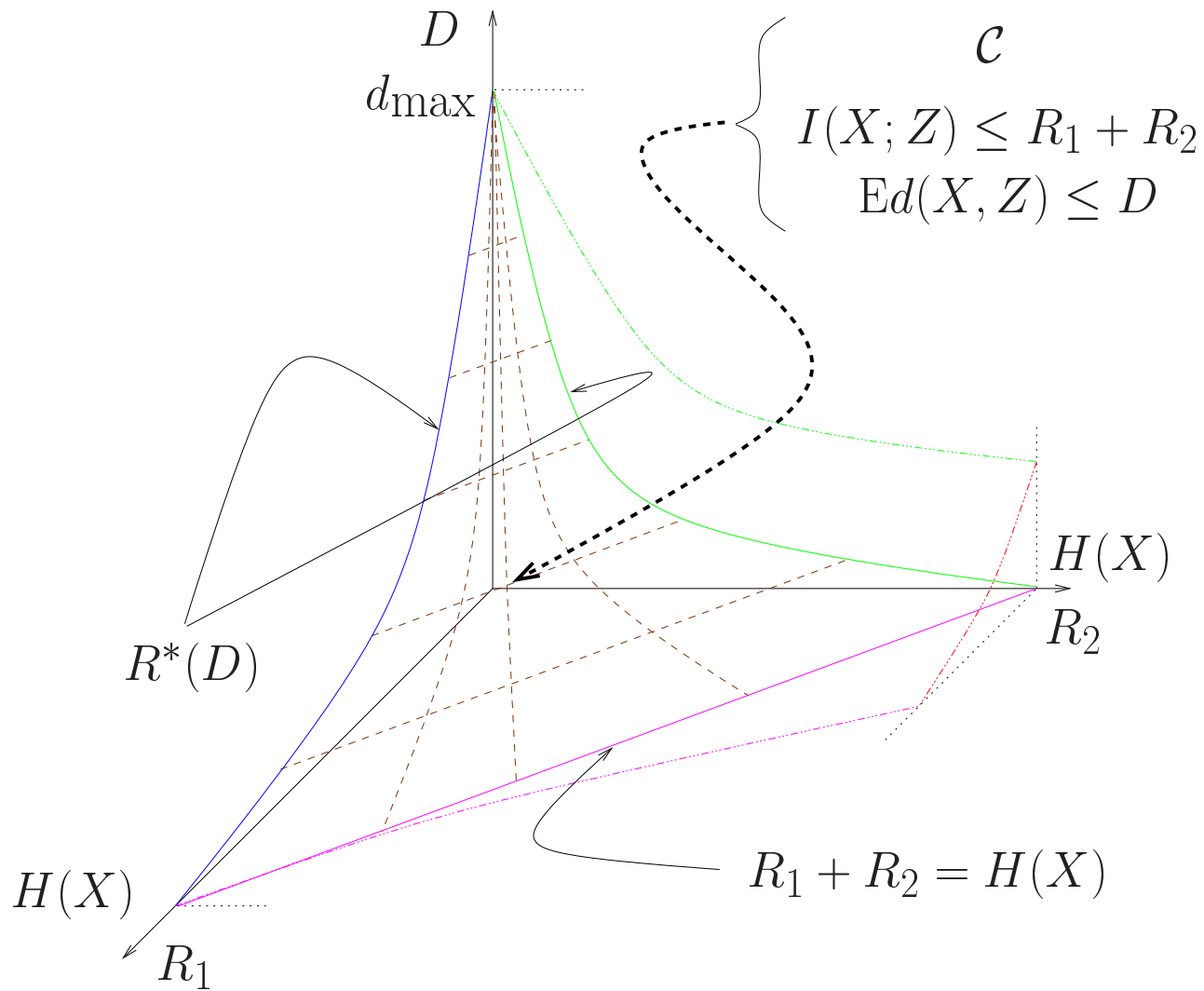

$$A_1^* \neq C = A = B_1^*$$

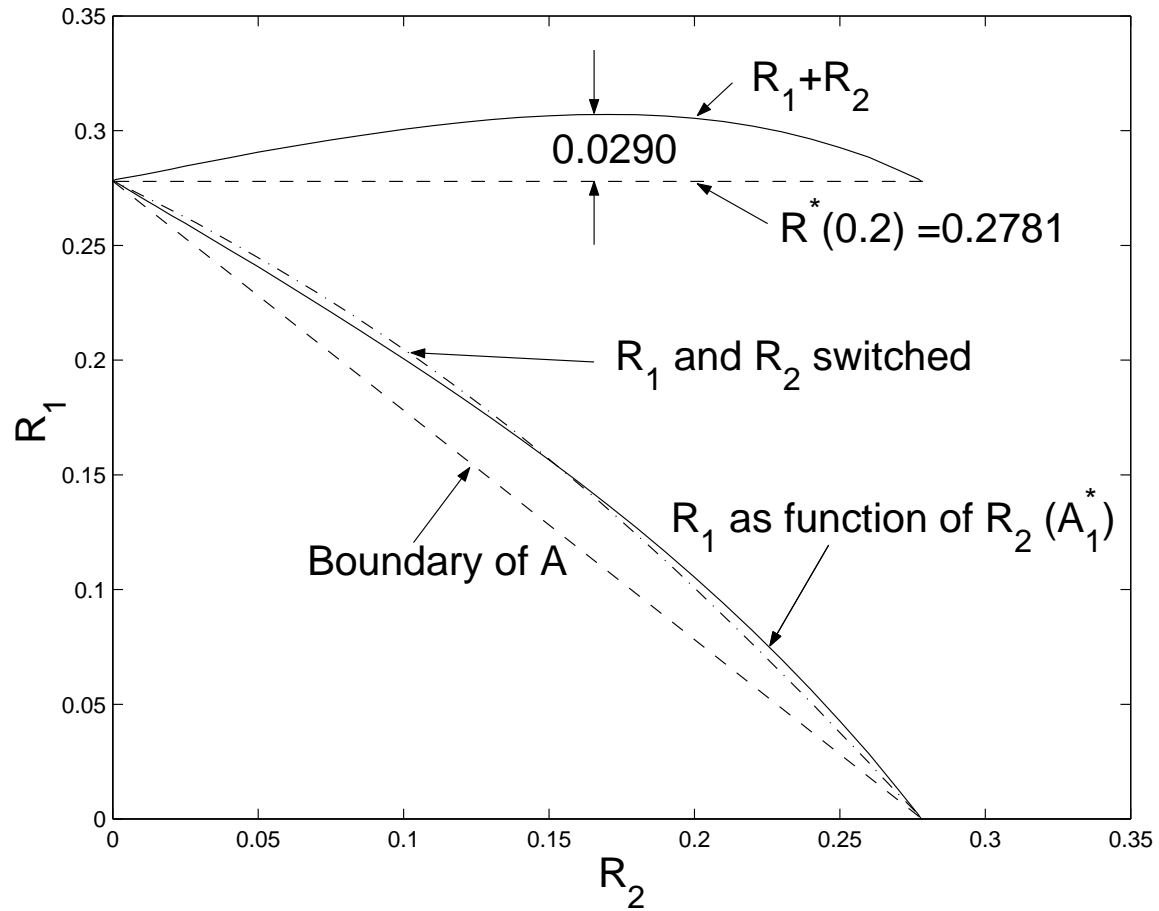

Open Questions

1. Condition for first-order description
2. Topology of \mathcal{A}_n^*
3. Computational algorithm