

DESIGN OF A SWITCHED-CAPACITOR FILTER FOR VOICE BAND SIGNALS

Li Ping¹, R.C.J.Taylor², R.K.Henderson³ and J.I.Sewell⁴

(1) Department of Electrical and Electronic Engineering, University of Melbourne, Victoria, Australia.

(2) Wolfson Microelectronics Ltd, Bernard Terrace, Edinburgh EH8 9NX, U.K.

(3) CSEM, Neuchatel, Switzerland

(4) Department of Electronics and Electrical Engineering, University of Glasgow, Glasgow G12 8QQ, U.K.

ABSTRACT

Conventional SC realisations of wide band filters demand large capacitance spread and exhibit serious sensitivity problems. The UL-LU structure is a ladder type simulation which demonstrates superior sensitivity performance and maintains low capacitance spread. Results from fabricated devices confirm the predicted properties.

INTRODUCTION

The voice band frequency range normally extends from 300Hz to 4KHz. The difficulty of designing filters in this range is that the relative bandwidth, defined by,

$RBW = (\omega^+ - \omega^-)/\omega_m$ $\omega_m = (\omega^+ - \omega^-)1/2$ (1)

is quite high. Switched-capacitor (SC) realisations of such wide band filters will have large capacitance spread and serious sensitivity problems.

LUD type ladder simulations have been proposed as alternatives to conventional filter structures. In this paper, a novel variant of the LUD simulation method will be presented yielding circuits with special application to voice band filtering. The design of a practical circuit for a mobile telephone application will be illustrated. It has low capacitance spread and low sensitivity which are important to reduce silicon area and ease the design requirements of the amplifiers and switches compared to other solutions [1].

WIDEBAND FILTER DESIGN

An audio receive filter for mobile telephony applications typically has a wide passband which extends from 300Hz to 3KHz and exhibits a -20dB/decade slope for frequency de-emphasis. A notch is included to remove unwanted mixed down frequencies which are close to the upper passband edge.

If the specification is met by a function with an elliptic-type zero distribution a very large capacitance spread will be incurred. The zeroes in the lower stopband create very large time constants which require large capacitors. Alternatively, if these zeroes are avoided by choosing an all-pole approximation with zeroes at zero and infinite frequency the required order will be very high. A compromise is to use a function with all lower band zeroes at zero frequency and elliptic-type zeroes in the upper stopband. Since the lower band edge of the filter is at low frequency, the movement of the lower band zeroes to the origin has only a slightly deleterious effect on the filter characteristic. Such a transfer function which meets the required template is shown in Fig.1. It is a 10th order function with a third order zero at the origin, a pair of imaginary axis zeroes and two pairs of mirror image real axis zeroes. The latter zeroes are specially placed to cause

negative element values in the passive prototype which cancel components in the SC simulation [2].

A comparison of sensitivity has been made for a number a different realisations [3-5] and the results are shown in Fig.2. The sensitivity measure being used is:

$$s(\omega) = \left\{ \sum_i \left[\frac{c_i}{|H(\omega)|} \frac{\partial |H(\omega)|}{\partial c_i} \right]^2 \right\}^{1/2} \quad (2)$$

It can be seen that both left-LUD and coupled-biquad circuits suffer from a low frequency sensitivity peak, whereas the leapfrog and cascade-biquad circuits exhibit poorer sensitivity performance at the higher band edge. The new UL-LU structure maintains a low sensitivity over the whole passband. Table 1 gives a comparison of capacitance cost and highlights the penalty of choosing a leapfrog realisation. The conclusion of these studies is that the UL-LU structure offers the best solution to this filtering problem. Fig.3 shows the structure of a passive prototype synthesised from this transfer function. Note that the position of a series capacitor between the first and second nodes is required to ensure E-type terminations in the SC circuit realisation shown in Fig.4. The simpler structure of the filter towards the output is due to the cancellation of feedthrough capacitors by specially positioned real axis zeroes. The circuit uses a clock frequency of 128kHz and has been fabricated onto silicon using a 3 μ m single metal, double poly, 5V process. The size of the filter is 3027 μ m by 894 μ m which is relatively small considering the complexity of the response. Passband details of the measured frequency response can be seen in Fig.5. The response meets the template very well and over a number of devices there was hardly any deviation whatever, illustrating the low sensitivity of the filter.

DERIVATION OF THE UL-LU STRUCTURE

A brief derivation of the UL-LU method is given as it is a novel variant of the LUD circuit family [5]. Start from the nodal equation of a passive prototype ladder,

$$(sC + s^{-1}\Gamma + G)V = J \quad (3)$$

A bilinear transformation $s \rightarrow (2/T)(1-z^{-1})/(1+z^{-1})$ yields

$$\left[\frac{2}{T} \frac{1-z^{-1}}{1+z^{-1}} C + \frac{T}{2} \frac{1+z^{-1}}{1-z^{-1}} \Gamma + G \right] V = J \quad (4)$$

A pair of LDI integration operators is defined by

$$\Phi = 1/(1-z^{-1}) \quad \Psi = z^{-1}/(1-z^{-1}) \quad (5)$$

$$\text{Rearrange (4) as } \left(\frac{1}{\Psi} A + \Phi B + D \right) V = (1+z)J \quad (6a)$$

$$A = 2/TC+T/2\Gamma+G \quad B = 4T\Gamma \quad D = 2G \quad (6b)$$

$$\text{And let } A = U_a L_a \quad B = L_b U_b \quad (7)$$

$$\text{Define } W_a = \Psi^{-1}(L_a V + U_a^{-1} J) \quad W_b = U_b V \quad D_s = D U_b^{-1} \quad (8)$$

The upper triangular matrix U_{as} and lower triangular matrix L_{bs} are defined (see Appendix) to satisfy the identity

$$U_{as} L_a = L_{bs} U_b \quad (9)$$

Then (6a) can be linearised w.r.t. the LDI operators (5) as

$$U_a W_a = -[(\Phi L_b + D_s) W_b] - J \quad (10a)$$

$$L_{bs} W_b = \Psi U_{bs} W_a - U_{as} U_a^{-1} J \quad (10b)$$

Notice now that the output is w_{bn} . As U_b is upper triangular w_{bn} differs from the output by only a constant. The realisation procedure for (10) by an SC circuit follows matrix methods [7-8].

CONCLUSIONS

This paper has examined the problem of designing voice-band SC filters with wideband specifications. Such filters do not have satisfactory realisations by conventional design techniques due to excessive area requirements or sensitivity to component value deviations. Low frequency notches which cause the large component spread are eliminated by designing a transfer function with lower band zeroes at the origin. A new ladder simulation structure has been proposed to overcome the sensitivity problems of other realisations. A 10th order filter with sloping passband response has been fabricated and the measured results verify that difficult audio frequency responses can be met practically using a relatively small area of silicon.

APPENDIX

When A and B are tridiagonal, L_a and U_b are also tridiagonal as well as triangular. Separate the diagonal and off-diagonal parts of the matrices

$$L_a = L_{ad} + L_{ao} \quad U_b = U_{bd} + U_{bo} \quad (11)$$

where L_{ad} and L_{bd} are diagonal matrices, L_{ao} has non-zero entries only on the first lower off diagonal and U_{bo} has non-zero entries only on the first upper off diagonal,

$$L_{ao} = \begin{bmatrix} 0 & & & & \\ * & 0 & & & \\ & & \ddots & & \\ & & & \ddots & \\ & & & & * & 0 \end{bmatrix} \quad U_{bo} = \begin{bmatrix} 0 & * & & & \\ & 0 & * & & \\ & & & \ddots & \\ & & & & \ddots & \\ & & & & & * & 0 \end{bmatrix}$$

where * stands for the non-zero entries. (12)

In (9) assume that U_{as} and L_{bs} are also tridiagonal and triangular matrices. Separate U_{as} and L_{bs} as

$$U_{as} = U_{asd} + U_{aso} \quad L_{bs} = L_{bsd} + L_{bso} \quad (13)$$

Equate the different parts of (9) according to the position of the non-zero entries,

$$U_{asd} L_{ao} = L_{bso} U_{bd} \quad (14a)$$

$$U_{aso} L_{ad} = L_{bsd} U_{bo} \quad (14b)$$

$$U_{asd} L_{ad} + U_{aso} L_{ao} = L_{bsd} U_{bd} + L_{bso} U_{bo} \quad (14c)$$

Since in (14a-c) the number of constraints is less than the number of variables, we can assign

$$L_{bsd} = I \quad (15)$$

which guarantees the realisability of system (10). From (14) and (15) we have

$$U_{asd} = (L_{ad} - L_{ao} U_{bd}^{-1} U_{bo})^{-1} \times (U_{bd} - U_{bo} L_{ad}^{-1} L_{ao}) \quad (16)$$

and the remaining variables can be solved from (14)

$$L_{bso} = U_{asd} L_{ao} U_{bd}^{-1} \quad U_{aso} = U_{bo} L_{ad}^{-1} \quad (17)$$

The matrices in (16) and (17) may be singular and the normal inverses do not exist. In these circumstances Moore-Penrose's generalised inverse can be used [9]. As the matrices in (16) and (17) are all diagonal, the procedure to obtain their Moore-Penrose inverse is very simple. The Moore-Penrose inverse of a diagonal matrix $D = \text{diag}[d_{11}, \dots, d_{nn}]$ is also a diagonal matrix given by $M = \text{diag}[m_{11}, \dots, m_{nn}]$ with

$$m_{ii} = \begin{cases} 1/d_{ii} & \text{if } d_{ii} \neq 0 \\ 0 & \text{if } d_{ii} = 0 \end{cases} \quad (18a)$$

$$m_{ii} = \begin{cases} 1/d_{ii} & \text{if } d_{ii} \neq 0 \\ 0 & \text{if } d_{ii} = 0 \end{cases} \quad (18b)$$

REFERENCES

- [1] P.Korhonen and J.Korhonen "An analogue CMOS circuit for mobile radio base station signal processing", Proc. ESSCIRC '89, pp 196-199.
- [2] R.K.Henderson, "Computer-aided design of switched-capacitor filters", Ph.D Thesis, University of Glasgow, 1989.
- [3] M. S.Lee and C.Chang, "Switched-capacitor filters using the LDI and bilinear transforms", IEEE Trans. CAS, vol.CAS-28, no.4, pp.265-270, April 1981.
- [4] K.Martin and A.S.Sedra, "Exact design of switched-capacitor bandpass filters using coupled biquad structures", IEEE Trans. CAS, vol.CAS-27, no. 6, pp.469-474, June 1980.
- [5] Li Ping and J.I.Sewell, "The LUD approach to switched-capacitor filter design", IEEE Trans. CAS, vol.CAS-34, no.12, pp.1611-1614, Dec. 1987.
- [6] H.J.Orchard, "Inductorless filters," Elect. Lett., vol. 2, pp. 224-225, June 1966.
- [7] Li Ping, "Theory and methodology of integrated ladder filter design", Ph.D. Thesis, University of Glasgow, 1990.
- [8] R.K.Henderson, Li Ping and J.I.Sewell, "A design program for digital and analogue filters : PANDDA", Proc. ECCTD '89, pp. 289-293, Brighton, U.K., Sept. 1989
- [9] C.R.Rao and S.K.Mitra, "Generalized inverse of matrices and its application", J.Wiley Inc, New York, 1971

STRUCTURE	TOTAL CAPACITANCE	CAPACITANCE SPREAD
UL-LU	746.4	113.1
LUD	703.3	112.5
LEFT-DIRECT	756.4	112.5
LEAPFROG	1734.7	957.8
BIQUAD	728.8	122.5

Table 1 Comparison of capacitance costs for filter realisation

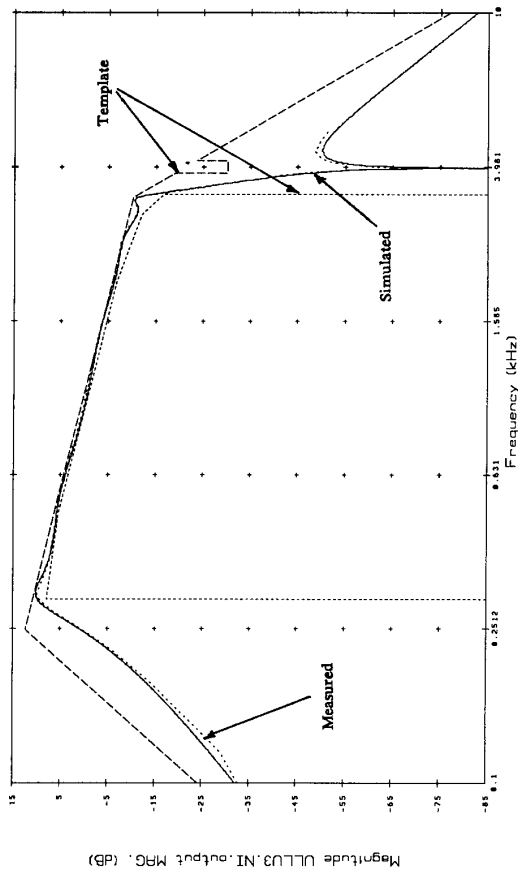

Fig. 1 Template and frequency responses of 10th order filter

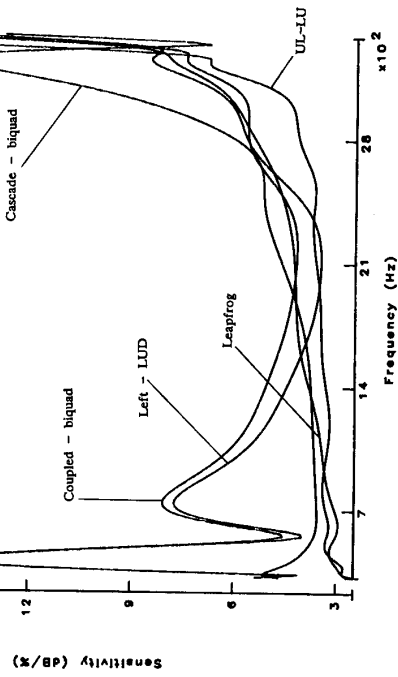

Fig. 2 Passband sensitivity comparison for 10th order filter realisations

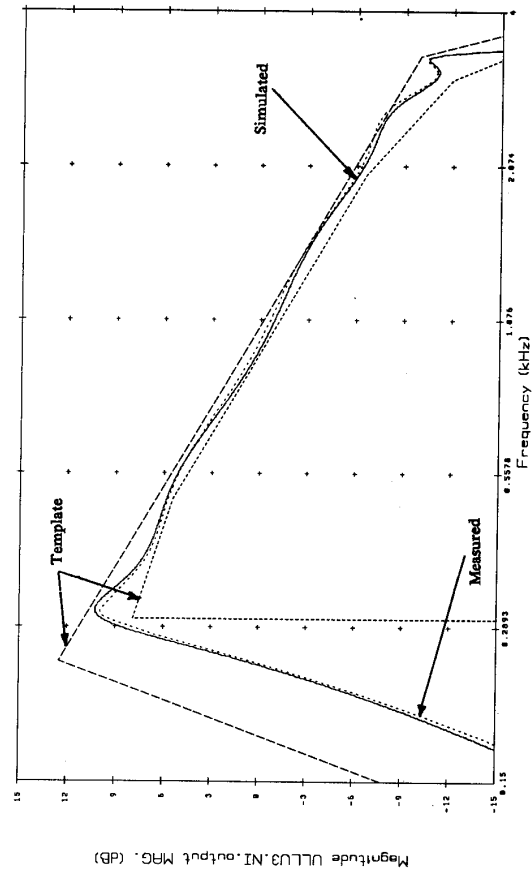

Fig. 5 Passband detail of 10th order filter

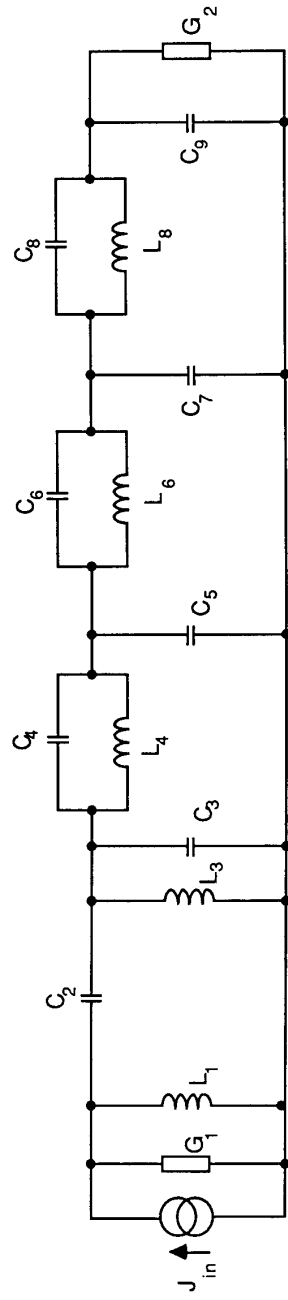

Fig. 3 10th order passive prototype

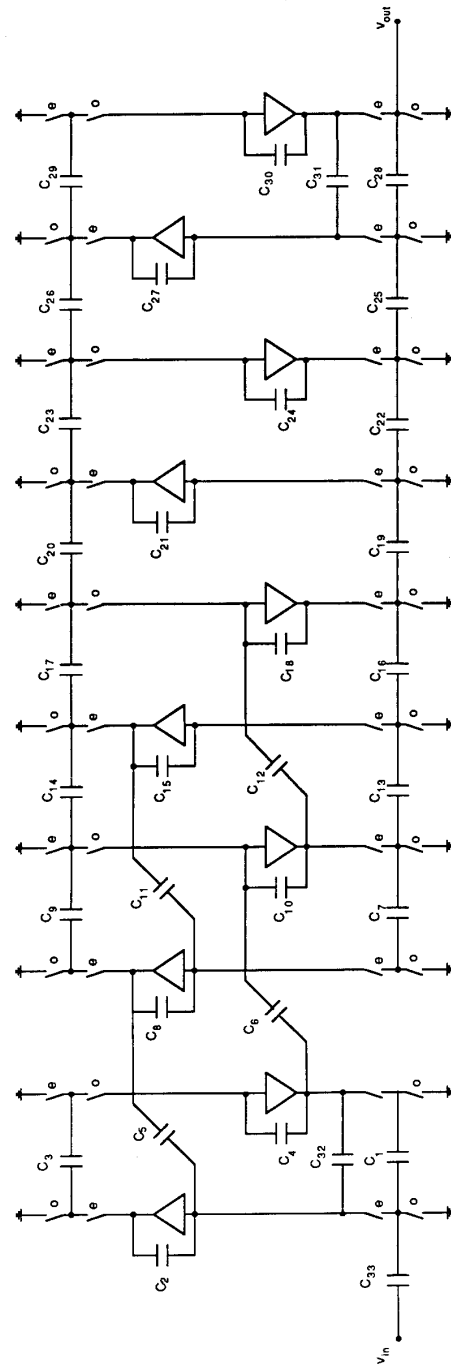

Fig. 4 UL-LU SC circuit realisation