

MATRIX METHODS FOR THE DESIGN OF TRANSCONDUCTOR LADDER FILTERS

N.P.J. Greer¹, R.K. Henderson², Li Ping³, and J.I. Sewell⁴

¹ Wolfson Microelectronics Ltd, 20 Bernard Terrace, Edinburgh, EH8 9NX, UK.

² CSEM SA, Maladiere 71, 2007 Neuchatel, Switzerland.

³ Dept of Electrical and Electronic Eng., University of Melbourne, Australia.

⁴ Dept of Electronics and Electrical Eng., University of Glasgow, G128QQ, UK.

Abstract

Matrix based methods for the design of transconductor ladder filters are presented. When transconductors with low impedance inputs are used these allow the realisation of highly selective bandpass responses using a single value of transconductance. If conventional transconductors are used, transconductor ratios can be restricted to the input and damping branches for any response. The new methods are illustrated by the design of a sixth order elliptic bandpass ladder.

1 Introduction

In recent years much research has been directed towards the development of continuous time transconductor filters as an alternative to switched capacitor (SC) filters, particularly in the frequency range 100kHz to 10MHz. Whilst many linear transconductor circuits have been presented in the literature [1,2,3,4], significant problems have impeded the design of active filter structures in which they might be applied.

The problem addressed in this paper is how to design ladder filters without recourse to ratioed transconductances. Ratioed transconductors are undesirable because the transistors which determine the value of a particular transconductor can vary in size within only a small range without suffering from poor matching in one extreme or producing significant parasitic capacitance and high power consumption in the other. Moreover it is inconvenient for a designer to have to produce a different set of ratioed transconductors for each new filter design. This problem is unique to transconductor filters since the corresponding variables in RC and SC filters (resistors and sampling capacitors respectively) can be scaled relatively freely.

Most methods used to derive active RC and SC filters from passive prototypes have been based, explicitly or otherwise, on the simulation of nodal voltages and inductor currents. Examples of such filters are leapfrog and coupled biquad ladders, as well as circuits obtained by simulating inductors using gyrators. These methods have been applied successfully to the design of lowpass transconductor ladders [1,3] but they cannot generally be applied to bandpass ladders without the use of ratioed transconductor inputs [2,4,5]. This is due to the fact that when the voltages of a coupled biquad bandpass filter are scaled for dynamic range the summing coefficients between biquads take values which are lower than the coefficients within each biquad by a factor typically close to the fractional bandwidth of

the filter. The problem is compounded for prototypes containing inductor loops or unequal termination resistors since these imply non-integer ratios that cannot be implemented by combinations of a unit transconductance.

In this paper we present matrix methods for the derivation of original transconductor bandpass ladders. A passive ladder can be represented by the matrix equation

$$J = (G+sC+s^{-1}\Gamma)V \quad (1)$$

where V and J are vectors representing the nodal voltages and input current source and G , C , and Γ are matrices representing the contributions of conductors, capacitors and inductors respectively. This equation is decomposed into two first order equations by the introduction of a vector of intermediate variables. To form the active filter, each first order equation is implemented by a set of transconductor-C building blocks.

A set of transconductor filters has been designed by the methods described here and is currently in fabrication on a 1μ CMOS process. These filters have centre/cutoff frequencies in the range 400kHz-4MHz. Even higher frequencies could be reached by the use of bipolar or GaAs technologies [6].

II Transconductor-C Building Blocks

The general first order transconductor-C building block has the transfer function:

$$V_{out} = \left[\sum_i g_i V_i + s \sum_j C_j V_j \right] / sC \quad (2)$$

It is desirable that only one value of g_j be used in a particular filter, but where more than one value is used the values should be in low integer ratios. Using a conventional transconductor, (2) is implemented by the circuit shown in Figure 1. In this case the capacitors C_j can represent only bidirectional coupling paths when driven by internal nodes, which can be a serious restriction. To obtain unidirectional coupling paths, a transconductor with low impedance current summing inputs [4] may be used, as shown in Figure 2. The low impedance input is marked Z and the integrating inputs are marked $g1+$, $g1-$, etc.

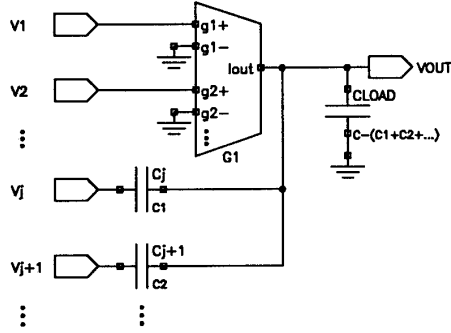

Figure 1 First order section using conventional transconductor

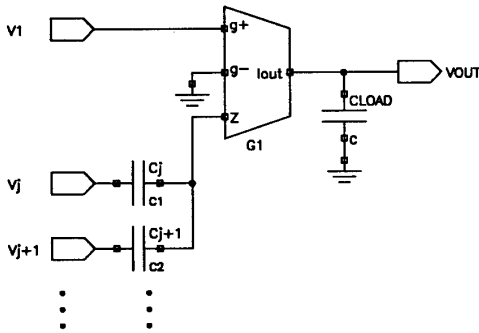

Figure 2 First order section using transconductor with low impedance inputs

III. Matrix Decompositions

i. Topological Decomposition

The inductor admittance matrix is factorised as:

$$\Gamma = ADA^T \quad (3)$$

where D is a diagonal matrix whose elements are the reciprocals of the inductances in the prototype, and A is a conventional incidence matrix. The auxiliary variables are defined by:

$$X = (sg)^{-1}DA^T V \quad (4)$$

where g is a constant with the dimensions of conductance. Equations (3) and (4) are substituted into (1) to obtain

$$CV = s^{-1}[J-GV-gAX]. \quad (5)$$

The design equations (4) and (5) can be used to obtain

conventional lowpass leapfrog filters. However new structures are required for the design of realisable bandpass filters. These are provided by the following two decompositions.

ii. Left Inverse Decomposition

The auxiliary variables are defined by

$$X = sCVg^{-1} \quad (6)$$

and (6) is substituted into (1), giving

$$gX = J-GV-s^{-1}\Gamma V. \quad (7)$$

The design equations are obtained by rearranging (6) and multiplying (7) by the inverse of Γ :

$$g^{-1}CV = s^{-1}X \quad (8)$$

$$g\Gamma^{-1}X = -s^{-1}V + \Gamma^{-1}[J-GV]. \quad (9)$$

iii. Right Inverse Decomposition

This proceeds as for Left Inverse Decomposition, except that X is defined:

$$gX = s^{-1}\Gamma V. \quad (10)$$

The resulting design equations are:

$$g\Gamma^{-1}X = s^{-1}V \quad (11)$$

$$g^{-1}CV = s^{-1}[g^{-1}(J-GV)-X]. \quad (12)$$

IV. Bandpass Transconductor Ladders

If transconductors with low impedance inputs are available [4] the Left Inverse (LI) decomposition should be used. In (8) and (9) the only integrated terms are vectors so a single value of transconductance can be used throughout the whole filter. This value g is selected such that V and X are correctly scaled for dynamic range. We set $g = 1/\alpha R$ where the scaling parameter α often takes an optimum value close to the fractional bandwidth of the filter. As an example a sixth order elliptic bandpass filter with 400kHz centre frequency, 40kHz bandwidth, 0.1dB passband ripple and 50dB stopband attenuation has been designed. The passive prototype for this response, shown in Figure 3, can be described by the matrices:

$$J = \begin{pmatrix} \frac{V_{in}}{R_1} \\ 0 \\ 0 \end{pmatrix}, \quad V = \begin{pmatrix} V_1 \\ V_2 \\ V_3 \end{pmatrix}, \quad G = \begin{pmatrix} \frac{1}{R_1} & 0 & 0 \\ 0 & 0 & 0 \\ 0 & 0 & \frac{1}{R_2} \end{pmatrix},$$

$$C = \begin{pmatrix} C_1+C_2 & -C_2 & 0 \\ -C_2 & C_2+C_3+C_4 & -C_4 \\ 0 & -C_4 & C_4+C_5 \end{pmatrix}.$$

$$\Gamma = \begin{pmatrix} \frac{1}{L_1+L_2} & \frac{-1}{L_2} & 0 \\ \frac{-1}{L_2} & \frac{1}{L_2+L_3+L_4} & \frac{-1}{L_4} \\ 0 & \frac{-1}{L_4} & \frac{1}{L_4+L_5} \end{pmatrix} \quad (13a-e)$$

Substituting (13a-e) into (8) and (9) and implementing each row by a first order section (Figure 2) leads to the transconductor ladder shown in Figure 4. Using the transconductor described in [4] this circuit was simulated with SPICE models for a 1 μ p-well CMOS process. The magnitude response is given in Figure 5.

If transconductors with low impedance inputs are not available, the Right Inverse (RI) Decomposition provides the best bandpass ladders. Conventional transconductors can be used to implement (11) and (12) because the only non-integrated terms are those arising from the off-diagonal elements of Γ^{-1} and C, which represent bidirectional coupling paths. Neither V nor X is premultiplied before integration, so no unrealisable summing coefficients are introduced. In order to scale the filter correctly for dynamic range a second (smaller) value of transconductance is usually required to realise the input branch and filter terminations. This use of a second transconductance value is acceptable because it can be chosen to be in integer ratio to the first and it is used only to represent the termination resistors which are the least sensitive components of the prototype. This compares favourably with a cascaded biquad ladder in which unrealisable transconductor ratios can occur throughout the filter.

LI and RI filters employ capacitive and resistive damping respectively, hence we can refer to them as "E-type" and "F-type" circuits by analogy with the terminations and terminology used for SC biquads [7].

V Conclusions

The inverse matrix methods allow the design of bandpass transconductor ladders which would not be realisable using conventional coupled-biquad or inductor simulation methods. The Topological Decomposition represents a formal method for the design of lowpass transconductor ladders. These

techniques have been used to design a set of high frequency CMOS transconductor ladder filters which are currently in fabrication. Experimental results will be published when available.

Acknowledgements

The authors wish to thank the Department of Trade and Industry (UK) and the Science and Engineering Research Council (UK) for financial support.

References

- [1] KRUMMENACHER, F., and JOEHL, N.: 'A 4MHz CMOS Continuous-Time Filter with On-Chip Automatic Tuning', IEEE J. Solid-State Circuits, 1988, SC-23, pp. 750-758
- [2] KHORRAMABADI, H., and GRAY, P. R.: 'High-Frequency CMOS Continuous-Time Filters', IEEE J. Solid-State Circuits, 1984, SC-19, pp. 939-948
- [3] PENNOCK, J. L.: 'CMOS Triode Transconductor For Continuous Time Active Integrated Filters', Electron. Lett., 1985, 21, pp. 817-818
- [4] GREER, N. P. J., and DENYER, P. B.: 'A New Folded Cascode Transconductor For Bandpass Ladder Filters', accepted for publication in IEE Proceedings Part G
- [5] TAN, M. A., and SCHAUMANN, R.: 'Simulating General-Parameter LC-Ladder Filters for Monolithic Realizations with Only Transconductance Elements and Grounded Capacitors', IEEE Trans. Circuits Syst., 1989, CAS-36, pp. 229-308
- [6] HAIGH, D. G., and TOUMAZOU C.: 'High Frequency Gallium Arsenide Linearised Transconductor for Communications', Electron. Lett., 1990, 26, pp. 497-498
- [7] FLEISCHER, P. E., and LAKER, K. R.: 'A Family of Active Switched Capacitor Biquad Building Blocks', Bell Syst. Tech. J., 1979, 58, pp. 2235-2269

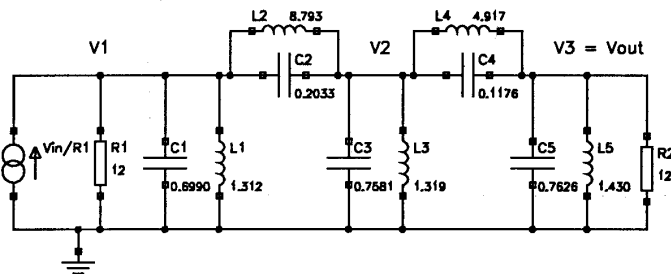

Figure 3 Sixth order elliptic bandpass prototype

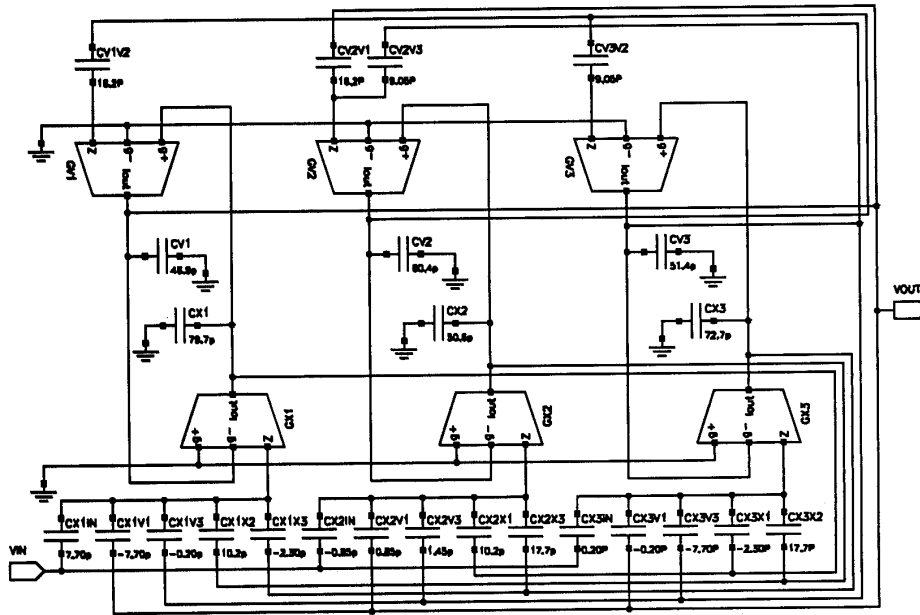

Figure 4 Left inverse transconductor ladder (single ended equivalent circuit)

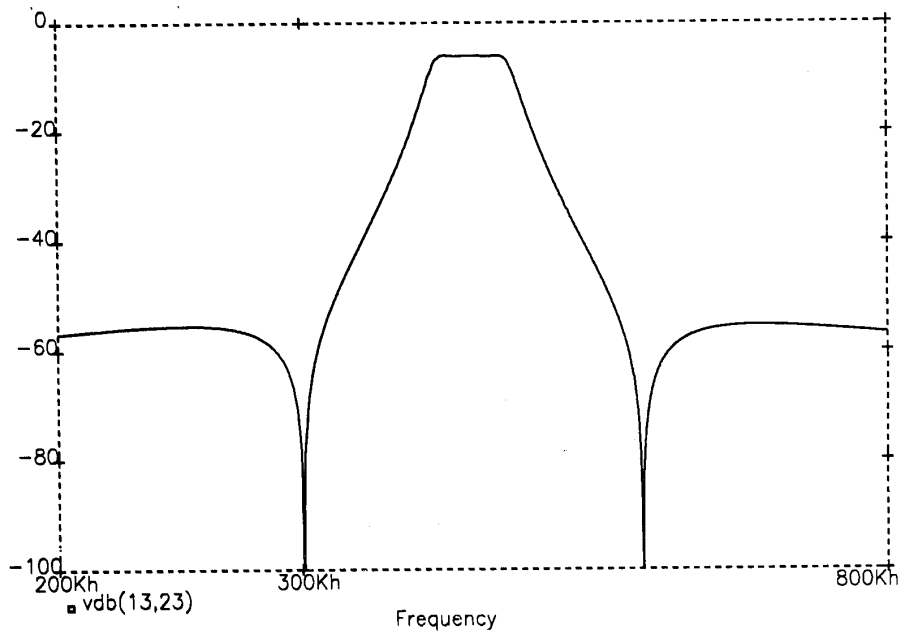

Figure 5 Simulated response of left inverse elliptic bandpass ladder