

Low-Complexity Iterative Detection in Multi-User MIMO ISI Channels

Xiaojun Yuan, Qinghua Guo, and Li Ping, *Senior Member, IEEE*

Abstract—We propose a low-cost detection strategy for multi-user multiple-input-multiple-output (MIMO) systems with inter-symbol interference (ISI). The cyclic prefix (CP) technique is assumed. The proposed detection algorithm is derived in a very concise manner based on some elegant properties of circulant matrices. We show that multi-user detection and equalization can be carried out jointly and efficiently.

Index Terms—Cyclic prefix, frequency domain equalization (FDE), iterative (turbo) detection, multi-user MIMO ISI channels.

I. INTRODUCTION

MULTI-USER multiple-input-multiple-output (MIMO) systems may suffer from several forms of interference, namely, multiple-access interference (MAI), cross-antenna interference (CAI), and inter-symbol interference (ISI). Time-domain detection techniques [1]–[4] entail high complexity, especially in channels with large delay spread. It remains a challenging issue to handle the combined effect of these types of interference efficiently.

In this letter, we propose a simple, unified solution to the above problem. Our work is motivated by the recent progress in the cyclic prefix (CP) technique for single carrier systems and frequency domain equalization (FDE) [5]–[9]. The proposed detection algorithm is derived concisely based on some elegant properties of circulant matrices. Its performance is comparable to that of its time-domain counterparts [2]–[4], but its complexity is much lower, and particularly, is independent of the channel delay spread.

II. SYSTEM MODEL AND JOINTLY GAUSSIAN APPROACH

A. Linear System Model

Consider a generic linear discrete-time system modeled as

$$\mathbf{r} = \mathbf{H}\mathbf{x} + \boldsymbol{\eta} \quad (1)$$

where \mathbf{r} is an observation vector, \mathbf{H} a channel matrix, $\mathbf{x} = \{x_j\}$ a transmitted signal vector, $\boldsymbol{\eta}$ an additive white Gaussian noise (AWGN) vector with zero mean and covariance $\sigma^2\mathbf{I}$, and \mathbf{I} is an identity matrix with proper size. Assume that \mathbf{H} and $\boldsymbol{\eta}$ are real and that \mathbf{x} is binary phase shift keying (BPSK) modulated. More general cases are dealt with in Section IV.

Manuscript received April 27, 2007; revised August 15, 2007. This work was supported by City University of Hong Kong under a strategic grant (Project No. 7001812). The associate editor coordinating the review of this manuscript and approving it for publication was Dr. Xiang-Gen Xia.

The authors are with the Department of Electronic Engineering, City University of Hong Kong, Kowloon, Hong Kong (e-mail: xjyuan@cityu.edu.hk; qh.guo@student.cityu.edu.hk; eeliping@cityu.edu.hk).

Digital Object Identifier 10.1109/LSP.2007.910331

B. Estimation Problem

The overall detection involves iteration between a soft interference canceller (for MAI, CAI, and ISI) and a decoder (or, for a multiple-access system, a bank of decoders, one for each user). Interested readers may refer to [2]–[4] for details. Our focus is on the efficient implementation of the soft interference canceller that produces the extrinsic log-likelihood ratio (LLR) for each x_j , i.e. (for BPSK)

$$\lambda_j \equiv \ln \frac{p(\mathbf{r}|x_j = +1)}{p(\mathbf{r}|x_j = -1)}, \quad j = 0, 1, 2, \dots \quad (2)$$

based on the feedback information from the decoder(s).

The exact evaluation of (2) is prohibitively complicated in the presence of the joint effect of MAI, CAI, and ISI. Instead, we follow the jointly Gaussian technique [4], which is equivalent to the linear minimum-mean-square-error (MMSE) approach [2] as they both make Gaussian assumptions.

C. Jointly Gaussian Approach

Assume that \mathbf{H} is known at the receiver. Denote by $\mathbf{E}(\mathbf{x})$ and \mathbf{V} the *a priori* mean and covariance matrix of \mathbf{x} , respectively (resp.). Assume that the entries of \mathbf{x} are independent and so \mathbf{V} is a diagonal matrix: $\mathbf{V} = \text{diag}\{v_0, v_1, v_2, \dots\}$, where v_j is the *a priori* variance of x_j . As shown in [2]–[4], $\mathbf{E}(\mathbf{x})$ and \mathbf{V} can be computed by the feedback information from the decoder(s). Let us focus on the estimation of a particular bit x_j and treat all the other bits as interference. We can rewrite (1) as

$$\mathbf{r} = \mathbf{h}_j x_j + \boldsymbol{\xi}_j$$

where \mathbf{h}_j is the j th column of \mathbf{H} , and $\boldsymbol{\xi}_j \equiv \sum_{j' \neq j} \mathbf{h}_{j'} x_{j'} + \boldsymbol{\eta}$. The covariance matrixes of \mathbf{r} and $\boldsymbol{\xi}_j$, resp., are given by $\mathbf{R} = \mathbf{H}\mathbf{V}\mathbf{H}^T + \sigma^2\mathbf{I}$ and $\mathbf{R}_j = \mathbf{R} - v_j \mathbf{h}_j \mathbf{h}_j^T$. We further assume that $\boldsymbol{\xi}_j$ is a jointly Gaussian random vector, which can be justified by the central limit theorem. Then, for a real \mathbf{H} , (1) can be evaluated as follows:

$$\begin{aligned} \lambda_j &= \ln \frac{\exp\left(-\frac{1}{2}(\mathbf{r} - \mathbf{h}_j - \mathbf{E}(\boldsymbol{\xi}_j))^T \mathbf{R}_j^{-1} (\mathbf{r} - \mathbf{h}_j - \mathbf{E}(\boldsymbol{\xi}_j))\right)}{\exp\left(-\frac{1}{2}(\mathbf{r} + \mathbf{h}_j - \mathbf{E}(\boldsymbol{\xi}_j))^T \mathbf{R}_j^{-1} (\mathbf{r} + \mathbf{h}_j - \mathbf{E}(\boldsymbol{\xi}_j))\right)} \\ &= 2\mathbf{h}_j^T \mathbf{R}_j^{-1} (\mathbf{r} - \mathbf{H}\mathbf{E}(\mathbf{x}) + \mathbf{h}_j \mathbf{E}(x_j)). \end{aligned} \quad (3)$$

Applying the matrix inversion lemma to \mathbf{R}_j^{-1} , we rewrite (3) as

$$\lambda_j = 2 \cdot \frac{\mathbf{h}_j^T \mathbf{R}^{-1} (\mathbf{r} - \mathbf{H}\mathbf{E}(\mathbf{x})) + \mathbf{h}_j^T \mathbf{R}^{-1} \mathbf{h}_j \mathbf{E}(x_j)}{1 - v_j \mathbf{h}_j^T \mathbf{R}^{-1} \mathbf{h}_j}, \quad j = 0, 1, 2, \dots$$

or in a vector form as

$$\boldsymbol{\lambda} = 2(\mathbf{I} - \mathbf{V}\mathbf{U})^{-1} \left[\mathbf{H}^T \mathbf{R}^{-1} (\mathbf{r} - \mathbf{H}\mathbf{E}(\mathbf{x})) + \mathbf{U}\mathbf{E}(\mathbf{x}) \right] \quad (4)$$

where $\boldsymbol{\lambda} \equiv [\lambda_0, \lambda_1, \lambda_2, \dots]^T$ and $\mathbf{U} \equiv (\mathbf{H}^T \mathbf{R}^{-1} \mathbf{H})_{\text{diag}}$ with $(\cdot)_{\text{diag}}$ a diagonal matrix consisting of the diagonal of the matrix in the parentheses. We will show that (4) can be efficiently implemented by exploiting the circulant property of the systems.

III. IMPLEMENTATION BASED ON CIRCULANT \mathbf{H}

A. Circulant Systems

Consider (1) over a single-user, single-input-single-output (SISO), quasi-static, ISI channel. The CP technique [5]–[9] can be used to transform the channel effect into a circular convolution with a corresponding circulant channel matrix \mathbf{H} as follows:

$$\mathbf{H} = \begin{bmatrix} h_0 & \cdots & h_2 & h_1 \\ h_1 & h_0 & & \\ \vdots & \ddots & \ddots & \vdots \\ h_{J-1} & \cdots & h_1 & h_0 \end{bmatrix} \quad (5)$$

where the j th row of \mathbf{H} , $\forall j$, is the cyclic shift of the first row by j positions, h_j the j th tap coefficient of the channel, and J the block length of \mathbf{x} . Now let \mathbf{F} be the normalized discrete Fourier transform (DFT) matrix with the (j, j') th entry given by $J^{1/2} \exp(-i2\pi jj'/J)$, and $i = \sqrt{-1}$. Thus, $\mathbf{F}\mathbf{F}^H = \mathbf{I}$. Also let $\{g_j\}$ be the DFT of $\{h_j\}$, i.e.,

$$g_j = J^{-1/2} \sum_{j'=0}^{J-1} h_{j'} \exp(-i2\pi jj'/J) \quad j = 0, \dots, J-1.$$

The following properties are well known for a circulant \mathbf{H} :

$$\mathbf{G} \equiv \mathbf{F}\mathbf{H}\mathbf{F}^H = J^{1/2} \text{diag}\{g_0, g_1, \dots, g_{J-1}\} \quad (6a)$$

$$\mathbf{H} = \mathbf{F}^H \mathbf{G} \mathbf{F}. \quad (6b)$$

B. Fast Implementation Technique

We approximate the feedback variances by their average, i.e., $v_0 = v_1 = v_2 = \dots = v_{J-1} = \bar{v}$. Then,

$$\mathbf{V} = \bar{v}\mathbf{I} \quad (7a)$$

and

$$\mathbf{F}\mathbf{V}\mathbf{F}^H = \mathbf{V}. \quad (7b)$$

This approximation can lead to greatly reduced complexity in implementing (4), whereas the related performance loss is usually not significant (see Fig. 2). Based on (6) and (7)

$$\mathbf{R} = \mathbf{F}^H \mathbf{G} \mathbf{F} \mathbf{V} \mathbf{F}^H \mathbf{G}^H \mathbf{F} + \sigma^2 \mathbf{I} = \mathbf{F}^H (\bar{v} \mathbf{G} \mathbf{G}^H + \sigma^2 \mathbf{I}) \mathbf{F}$$

and

$$\mathbf{H}^T \mathbf{R}^{-1} \mathbf{H} = \mathbf{F}^H \mathbf{G}^H (\bar{v} \mathbf{G} \mathbf{G}^H + \sigma^2 \mathbf{I})^{-1} \mathbf{G} \mathbf{F}.$$

Clearly, both \mathbf{R} and $\mathbf{H}^T \mathbf{R}^{-1} \mathbf{H}$ are circulant. Furthermore, \mathbf{U} can be expressed as

$$\mathbf{U} = (\mathbf{H}^T \mathbf{R}^{-1} \mathbf{H})_{\text{diag}} = u\mathbf{I} \quad (8)$$

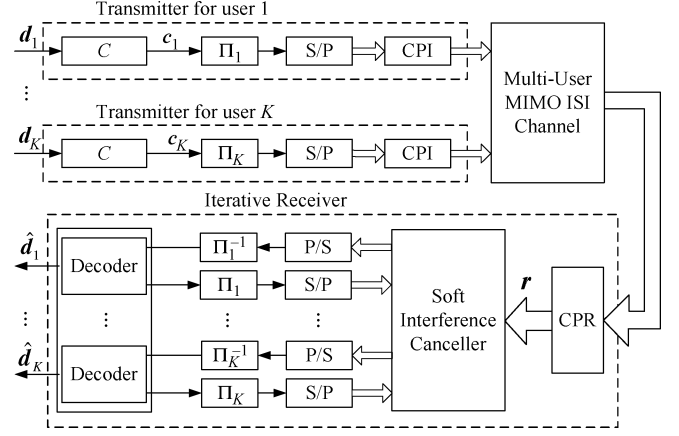

Fig. 1. Transmitter and (iterative) receiver structures for a coded multi-user MIMO system, where Π_k and Π_k^{-1} , resp., denote the random interleaver and the corresponding de-interleaver for user k , S/P and P/S, resp., denote the serial-to-parallel and parallel-to-serial converters, and CPI and CPR, resp., are for inserting and removing CP.

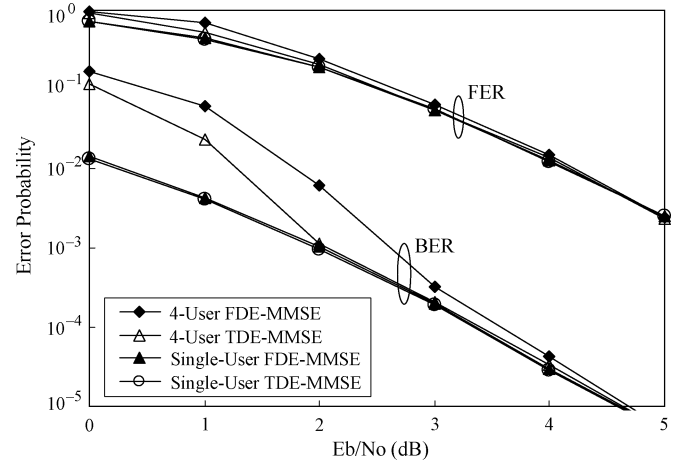

Fig. 2. BER/FER performance of the system in Fig. 1 in quasi-static Rayleigh fading channels with $K = 4$, $N = M = 2$, and $L = 4$. Single-user performance is also included for comparison.

with $u \equiv \sum_{j=0}^{J-1} |g_j|^2 (\bar{v} J |g_j|^2 + \sigma^2)^{-1}$. Then (4) can be rewritten as

$$\boldsymbol{\lambda} = 2(1 - \bar{v}u)^{-1} \left[\mathbf{F}^H \mathbf{G}^H (\bar{v} \mathbf{G} \mathbf{G}^H + \sigma^2 \mathbf{I})^{-1} \times (\mathbf{F} \mathbf{r} - \mathbf{G} \mathbf{F} \mathbf{E}(\mathbf{x})) + u \mathbf{E}(\mathbf{x}) \right]. \quad (9)$$

Equation (9) shows that $\boldsymbol{\lambda}$ can be fast evaluated as follows.

Algorithm 1

- Step 1) Compute $\mathbf{F} \mathbf{r} - \mathbf{G} \mathbf{F} \mathbf{E}(\mathbf{x})$.
- Step 2) Left-multiply the result of Step 1 by a diagonal matrix $\mathbf{G}^H (\bar{v} \mathbf{G} \mathbf{G}^H + \sigma^2 \mathbf{I})^{-1}$.
- Step 3) Left-multiply the result of Step 2 by \mathbf{F}^H , add $u \mathbf{E}(\mathbf{x})$, and scale the result by $2(1 - \bar{v}u)^{-1}$.

In Steps 1 and 3, multiplication by \mathbf{F} and \mathbf{F}^H can be realized by fast Fourier transform (FFT) and inverse FFT (IFFT), resp.

The normalized cost (in terms of operations per entry of \mathbf{x} , with each operation including one multiplication and one addition) of Algorithm 1 is $O(\log_2 J)$. It can be shown that Algorithm 1 is equivalent to the FDE [7].

IV. EXTENSION TO PARTITIONED-CIRCULANT SYSTEMS

We now discuss MIMO, multi-user, complex, and quadrature-phase-shift-keying (QPSK) situations.

A. Partitioned-Circulant Systems

First consider a single-user MIMO system with N transmit and M receive antennas. Let $\mathbf{H}^{(m,n)}$ be the channel matrix between the n th transmit and m th receive antennas, and \mathbf{x}_n the signal vector transmitted via the n th transmit antenna. The CP technique can be applied to each \mathbf{x}_n to make $\mathbf{H}^{(m,n)}$ circulant. \mathbf{H} in (1) can then be expressed in a *partitioned-circulant* form as

$$\mathbf{H} = \begin{bmatrix} \mathbf{H}^{(1,1)} & \dots & \mathbf{H}^{(1,N)} \\ \vdots & \ddots & \vdots \\ \mathbf{H}^{(M,1)} & \dots & \mathbf{H}^{(M,N)} \end{bmatrix} \quad (10)$$

and correspondingly

$$\mathbf{x} = [\mathbf{x}_1^T, \mathbf{x}_2^T, \dots, \mathbf{x}_N^T]^T.$$

B. Fast Implementation Technique

Define

$$\mathbf{F}_L \equiv \text{diag}\{\underbrace{\mathbf{F}, \mathbf{F}, \dots, \mathbf{F}}_{M \text{ repeats}}\} \text{ and } \mathbf{F}_R \equiv \text{diag}\{\underbrace{\mathbf{F}, \mathbf{F}, \dots, \mathbf{F}}_{N \text{ repeats}}\} \quad (11)$$

where \mathbf{F} is the $J \times J$ DFT matrix defined earlier. It is easy to see that \mathbf{F}_L and \mathbf{F}_R are both unitary, i.e.,

$$\mathbf{F}_L \mathbf{F}_L^H = \mathbf{I} \quad \text{and} \quad \mathbf{F}_R \mathbf{F}_R^H = \mathbf{I}. \quad (12)$$

Define

$$\mathbf{G} \equiv \mathbf{F}_L \mathbf{H} \mathbf{F}_R^H. \quad (13a)$$

Consequently

$$\mathbf{H} = \mathbf{F}_L^H \mathbf{G} \mathbf{F}_R. \quad (13b)$$

Denote by \mathbf{V}_n the covariance matrix of \mathbf{x}_n that is approximated by a diagonal matrix

$$\mathbf{V}_n = \bar{v}_n \mathbf{I}, \quad \text{for } n = 1, 2, \dots, N$$

where $\bar{v}_n, \forall n$, represents the average variance of the entries in \mathbf{x}_n . Then

$$\mathbf{V} = \text{diag}\{\bar{v}_1 \mathbf{I}, \bar{v}_2 \mathbf{I}, \dots, \bar{v}_N \mathbf{I}\} \quad (14a)$$

and

$$\mathbf{F}_R \mathbf{V} \mathbf{F}_R^H = \mathbf{V}. \quad (14b)$$

Equations (13) and (14) are the counterparts in a partitioned-circulant system to (6) and (7) in a circulant system. If only one encoder is used, we can assume that all $\{\bar{v}_n\}$ are equal. When more than one decoder is involved (e.g., in a multi-user system), we allow unequal values for $\{\bar{v}_n\}$. Combining (4) with (12)–(14), we have

$$\lambda = 2(\mathbf{I} - \mathbf{V}\mathbf{U})^{-1} \left[\mathbf{F}_R^H \mathbf{G}^H (\mathbf{G}\mathbf{V}\mathbf{G}^H + \sigma^2 \mathbf{I})^{-1} \times (\mathbf{F}_L \mathbf{r} - \mathbf{G}\mathbf{F}_R \mathbf{E}(\mathbf{x})) + \mathbf{U}\mathbf{E}(\mathbf{x}) \right] \quad (15)$$

where

$$\mathbf{U} = \left(\mathbf{F}_R^H \mathbf{G}^H (\mathbf{G}\mathbf{V}\mathbf{G}^H + \sigma^2 \mathbf{I})^{-1} \mathbf{G}\mathbf{F}_R \right)_{\text{diag}}. \quad (16)$$

Viewing (15) as a counterpart of (9), we have the following algorithm.

Algorithm 2

- Step 1) Compute $\mathbf{F}_L \mathbf{r} - \mathbf{G}\mathbf{F}_R \mathbf{E}(\mathbf{x})$.
- Step 2) Left-multiply the result of Step 1 by $\mathbf{G}^H (\mathbf{G}\mathbf{V}\mathbf{G}^H + \sigma^2 \mathbf{I})^{-1}$.
- Step 3) Left-multiply the result of Step 2 by \mathbf{F}_R^H , add $\mathbf{U}\mathbf{E}(\mathbf{x})$, and scale the result by $2(\mathbf{I} - \mathbf{V}\mathbf{U})^{-1}$.

We now show how to implement Algorithm 2 efficiently. In Step 1, multiplication by \mathbf{F}_L (resp., \mathbf{F}_R) can be decomposed into M (resp., N) J -point FFTs with complexity $O(MJ \log J)$ (resp., $O(NJ \log J)$). Similarly, multiplication by \mathbf{F}_R^H in Step 3 can be realized by IFFTs with complexity $O(NJ \log J)$.

For Step 2, \mathbf{G} in (13) can be partitioned into

$$\mathbf{G} = \begin{bmatrix} \mathbf{G}^{(1,1)} & \dots & \mathbf{G}^{(1,N)} \\ \vdots & \ddots & \vdots \\ \mathbf{G}^{(M,1)} & \dots & \mathbf{G}^{(M,N)} \end{bmatrix} \quad (17)$$

where each $\mathbf{G}^{(m,n)}$ has the same size of $\mathbf{H}^{(m,n)}$ in (10). From (10)–(13) and (17), we have $\mathbf{G}^{(m,n)} = \mathbf{F}\mathbf{H}^{(m,n)}\mathbf{F}^H$, which implies that each $\mathbf{G}^{(m,n)}$ is diagonal and can be computed by the FFT. We will say that such a \mathbf{G} is *partitioned-diagonal*. The partitioned-diagonal property is preserved over inversion and multiplication by partitioned-diagonal matrixes. Thus, the cost for evaluating $\mathbf{G}\mathbf{V}\mathbf{G}^H$ is $O(JM^2N)$, and that for $(\mathbf{G}\mathbf{V}\mathbf{G}^H + \sigma^2 \mathbf{I})^{-1}$ by Gaussian elimination is $O(JM^3)$. Alternatively, $(\mathbf{G}\mathbf{V}\mathbf{G}^H + \sigma^2 \mathbf{I})^{-1}$ can be evaluated with $O(JM^2N)$ operations by invoking the matrix inversion lemma (similarly to (51-53) in [2]).

For \mathbf{U} in (16), $\mathbf{G}^H (\mathbf{G}\mathbf{V}\mathbf{G}^H + \sigma^2 \mathbf{I})^{-1} \mathbf{G}$ is also partitioned-diagonal. We can partition its diagonal into N parts as follows:

$$\left(\mathbf{G}^H (\mathbf{G}\mathbf{V}\mathbf{G}^H + \sigma^2 \mathbf{I})^{-1} \mathbf{G} \right)_{\text{diag}} = \text{diag}\{\tilde{\mathbf{G}}_1, \dots, \tilde{\mathbf{G}}_n, \dots, \tilde{\mathbf{G}}_N\}$$

where each $\tilde{\mathbf{G}}_n$ is a $J \times J$ diagonal sub-matrix. Then we have

$$\mathbf{U} = \text{diag}\{u_1 \mathbf{I}, \dots, u_n \mathbf{I}, \dots, u_N \mathbf{I}\}$$

$$\mathbf{H} = \begin{bmatrix} \mathbf{H}^{(1,1,1)} & \dots & \mathbf{H}^{(1,N,1)} & \dots & \mathbf{H}^{(1,1,k)} & \dots & \mathbf{H}^{(1,N,k)} & \dots \\ \vdots & \ddots & \vdots & \ddots & \vdots & \ddots & \vdots & \ddots \\ \mathbf{H}^{(M,1,1)} & \dots & \mathbf{H}^{(M,N,1)} & \dots & \mathbf{H}^{(M,1,k)} & \dots & \mathbf{H}^{(M,N,k)} & \dots \end{bmatrix} \quad (18)$$

with $u_n = J^{-1}\text{tr}(\tilde{G}_n)$, $\forall n$, where $\text{tr}(\cdot)$ denotes the trace operation. The extra cost involved is $O(JM^2N)$.

To summarize, the overall normalized cost of Algorithm 2 is $O((1 + M/N)\log J + M^2)$ (where the length of \mathbf{x} is NJ).

C. Extension to Complex Multi-User Systems

The generalization to a multi-user MIMO system is straightforward. Consider an approximately synchronized multiple-access MIMO system modeled by (1). Assume that the synchronization errors among users are within the range of CP length so that it can be treated together with the channel delay spread. Then we have (18) at the top of the page, where $\mathbf{H}^{(m,n,k)}$ is the channel matrix between the n th transmit and the m th receive antennas for user k , and is made circulant by the CP technique. Clearly, (18) has the same structure as (10), and so Algorithm 2 still applies. Let K be the number of users. The related normalized cost is $O((1 + M/(NK))\log J + M^2)$. When K is large, $NK \gg M$ and thus the normalized cost is roughly $O(\log J + M^2)$. This method is numerically very efficient for small or moderate M , with the normalized cost independent of K , N , and also the channel delay spread.

The treatment for a complex system is also straightforward. A complex system in (1) can be rewritten in a real form as

$$\begin{bmatrix} \text{Re}(\mathbf{r}) \\ \text{Im}(\mathbf{r}) \end{bmatrix} = \begin{bmatrix} \text{Re}(\mathbf{H}) & -\text{Im}(\mathbf{H}) \\ \text{Im}(\mathbf{H}) & \text{Re}(\mathbf{H}) \end{bmatrix} \begin{bmatrix} \text{Re}(\mathbf{x}) \\ \text{Im}(\mathbf{x}) \end{bmatrix} + \begin{bmatrix} \text{Re}(\boldsymbol{\eta}) \\ \text{Im}(\boldsymbol{\eta}) \end{bmatrix}. \quad (19)$$

With QPSK modulation, $\text{Re}(\mathbf{x})$ and $\text{Im}(\mathbf{x})$ in (19) may carry two separate sets of bits. When \mathbf{H} is partitioned-circulant, so are $\text{Re}(\mathbf{H})$ and $\text{Im}(\mathbf{H})$. Hence, Algorithm 2 can be applied directly to (19).

V. NUMERICAL RESULTS AND CONCLUSIONS

Consider a multi-user MIMO system with four users ($K = 4$), two transmit antennas ($N = 2$) for each user, and two receive antennas ($M = 2$) at the receiver end. The system structure is shown in Fig. 1. The ISI channel for each transmit-receive antenna pair has a uniform power delay profile with four independent complex-Gaussian-distributed taps ($L = 4$). The transmitter structure follows the interleave-division multiple-access (IDMA) principles [3]. More specifically, for each user k , the information vector \mathbf{d}_k is encoded by a rate-1/2 $(7, 5)_8$ convolutional code with information length 1024 followed by length-2

spreading. The spreading sequence is $(+1, -1)$ to remove the DC component. The coded bits are randomly interleaved and then QPSK modulated with Gray mapping. The resultant signal is divided into two streams (each padded with a CP), one for each transmit antenna. The rate of each user is 1 (without considering CP) and the system throughput is 4.

The simulated performance is shown in Fig. 2 where algorithm 2 is referred to as ‘‘FDE-MMSE.’’ An alternative method, referred to as ‘‘TDE-MMSE’’ in Fig. 2, is to directly implement (4) using matrix inversion. TDE-MMSE does not require CPs and thus can save the related overhead. (In this case, the overhead is $10 * \log(1027/1024) \approx 0.013$ dB that is negligible.) Also, TDE-MMSE does not involve the approximation in (7) or (14). For these reasons, from Fig. 2, TDE-MMSE has a marginal performance advantage over FDE-MMSE. However, by avoiding the matrix inversion, FDE-MMSE is much more computationally efficient.

In conclusion, we have established a unified matrix framework for the FDE-based MMSE estimation in iterative detection systems. We have proposed a simple and efficient detection technique to handle the joint effect of MAI, CAI, and ISI.

REFERENCES

- [1] M. C. Reed, C. B. Schlegel, P. D. Alexander, and J. A. Asenstorfer, ‘‘Iterative multiuser detection for CDMA with FEC: Near-single-user performance,’’ *IEEE Trans. Commun.*, vol. 46, no. 12, pp. 1693–1699, Dec. 1998.
- [2] X. Wang and H. V. Poor, ‘‘Iterative (turbo) soft interference cancellation and decoding for coded CDMA,’’ *IEEE Trans. Commun.*, vol. 47, no. 7, pp. 1046–1061, Jul. 1999.
- [3] L. Ping, L. Liu, K. Wu, and W. Leung, ‘‘Interleave division multiple access,’’ *IEEE Trans. Wireless Commun.*, vol. 5, no. 4, pp. 938–947, Apr. 2006.
- [4] X. Yuan, K. Wu, and L. Ping, ‘‘The jointly Gaussian approach to iterative detection in MIMO systems,’’ in *Proc. IEEE Int. Conf. Commun., ICC’06*, Istanbul, Turkey, Jun. 11–15, 2006.
- [5] 3rd Generation Partnership project, Technical Specification Group Radio Access Network, Physical Layer Aspects for Evolved UTRA (Release 7), 3GPP TR25.814 V1.0.1 (2005-11).
- [6] D. Falconer, S. Ariyavisitakul, A. Benyamin-Seeyar, and B. Eldson, ‘‘Frequency domain equalization for single-carrier broadband wireless systems,’’ *IEEE Commun. Mag.*, vol. 40, no. 4, pp. 58–66, Apr. 2002.
- [7] M. Tüchler and J. Hagenauer, ‘‘Turbo equalization using frequency domain equalizers,’’ in *Proc. Allerton Conf.*, Monticello, IL, Oct. 2000.
- [8] G. G. Raleigh and J. M. Cioffi, ‘‘Spatio-temporal coding for wireless communication,’’ *IEEE Trans. Commun.*, vol. 46, no. 3, pp. 357–366, Mar. 1998.
- [9] J. Jang, H. Won, and G. Im, ‘‘Cyclic prefixed single carrier transmission with SFBC over mobile wireless channels,’’ *IEEE Signal Processing Lett.*, vol. 13, no. 5, pp. 261–264, May 2006.