

EE5602

Active

RF and Microwave Techniques

Dr. Quan Xue (薛泉)

Room: G6504

Tel: 3442 4680

Email: eeqxue@cityu.edu.hk

Home page: <http://www.ee.cityu.edu.hk/~qxue/>

Preface

—General information about the course

Prerequisites

- **EE5601** Radio Frequency and Microwave Techniques

OR

- **EE4139** Radio Frequency and Microwave Techniques

Prerequisites in Contents

- S-parameters;
- Smith-chart;
- Matching networks;
- Characteristics of transmission lines.

Aims and Objectives

Provide
essential techniques for
RF and microwave
front-ends
design

Outcomes?

- **Have** a good understanding of infrastructure of RF Front-End
- **Grasp** concepts about system parameters about RF Front-End
- **Obtain** capability of designing key components for RF Front-End

What's Front-End

A typical wireless communications system

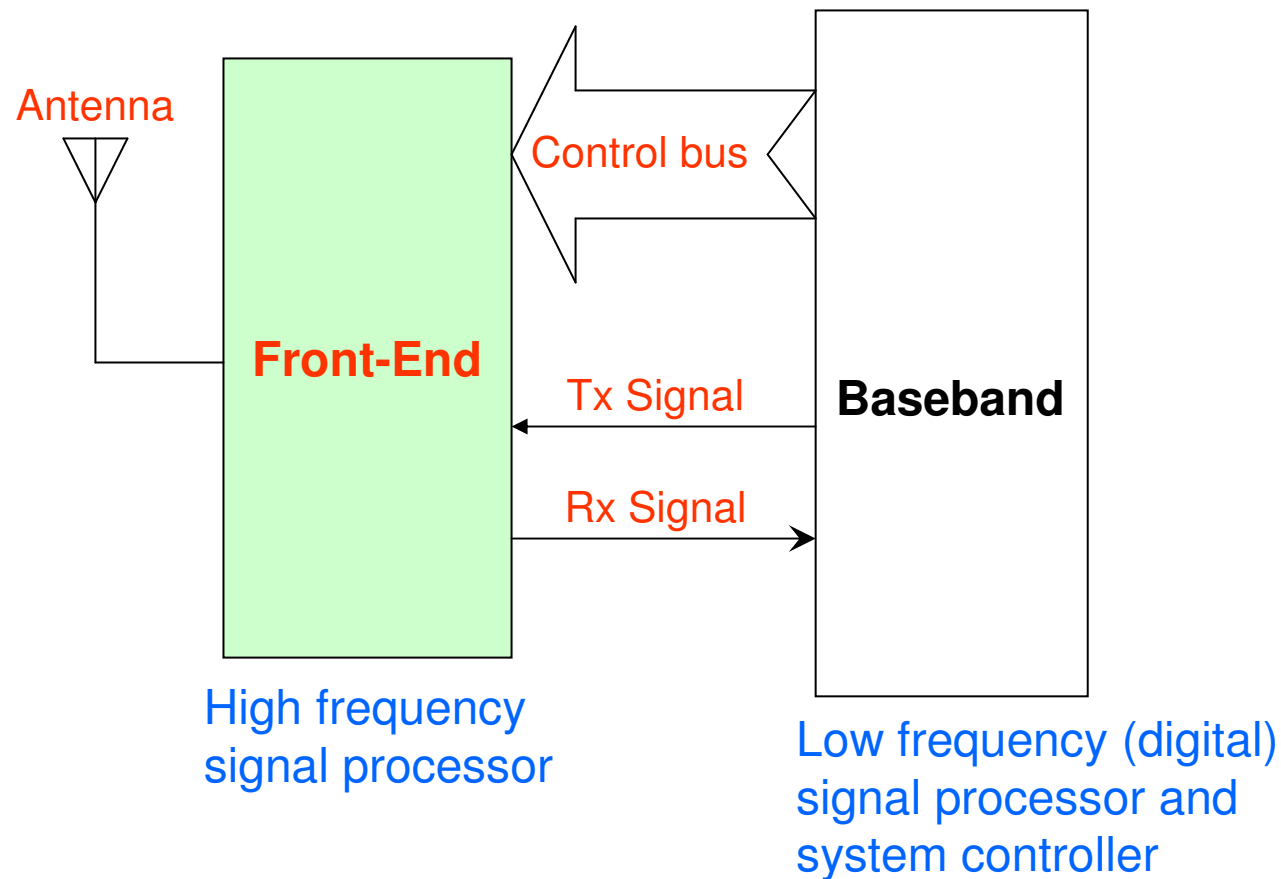

A typical front-end structure

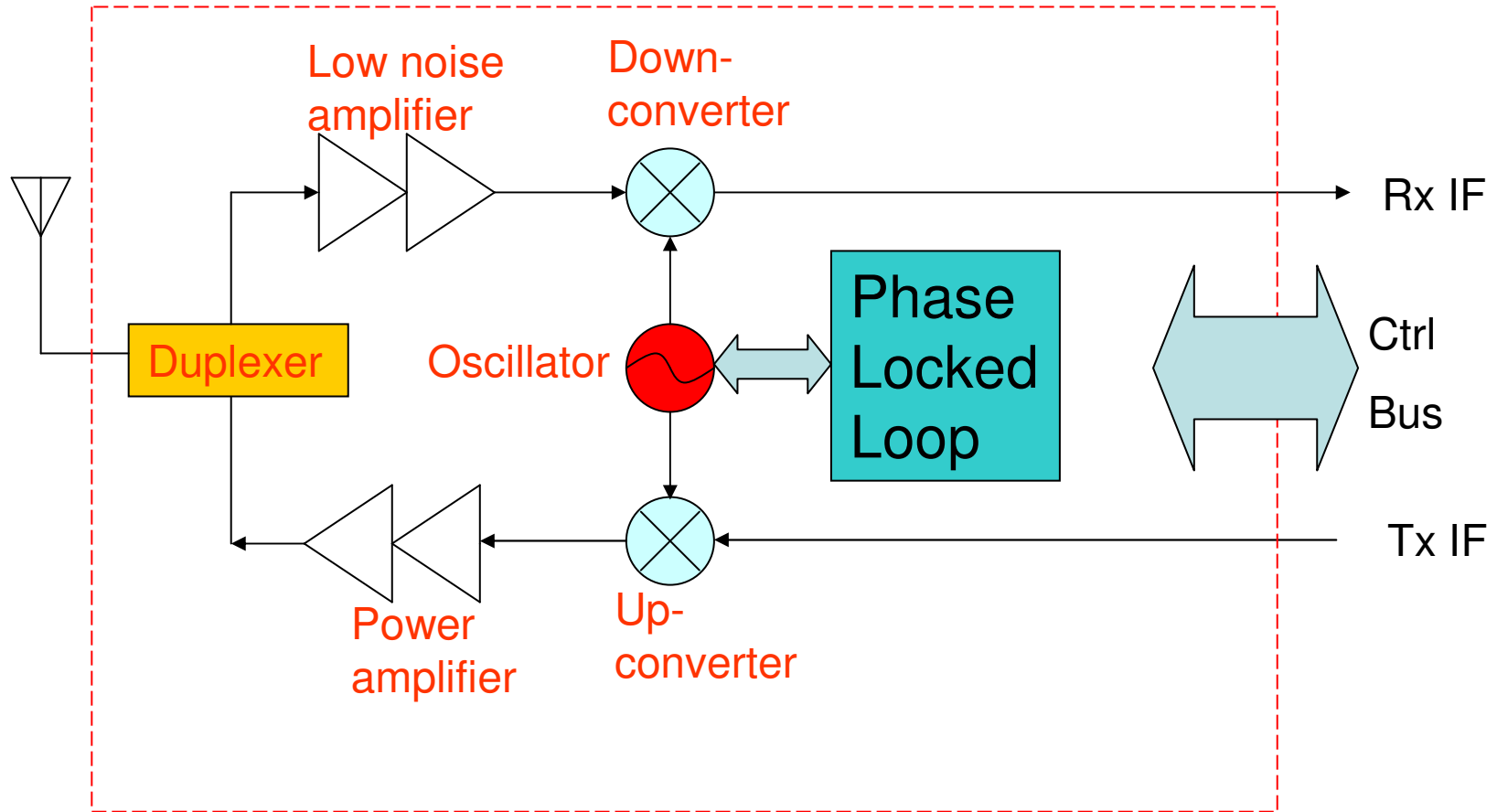

Contents of the Course

- **Part I** System Considerations
- **Part II** Key Components Designs
- **Part III** Introduction of Wireless Protocols

Contents of the Course

Part I System Consideration

- Chapter 1 Introduction to Wireless Techniques
- Chapter 2 Stability considerations
- Chapter 3 Gain considerations
- Chapter 4 Noise figure analysis

Part II Key Components Design

- Chapter 5 Small signal amplifiers
- Chapter 6 Large signal amplifiers
- Chapter 7 Oscillators
- Chapter 8 Phase locked loops
- Chapter 9 Mixers
- Chapter 10 Control Circuits

Part III Introduction of Wireless Protocols

- Chapter 11 Introduction of Wireless Protocols

Teaching and Tutorial

- **Two** hours of teaching and **One** hour of tutorial and experiment demonstrations every week (Including breaks);
- Two or three problems assignment every week;
- Optional supplementary materials after teaching hours

Assessment Pattern

- *Final Examination duration: 3 hours*, at the end of the semester, **60%** final score;
- Mid-term testing duration: **3 hours**, at the middle of the semester, **20%** final score;
- 10 coursework assignments, **10%** of final score;
- 11 attendances, **10%** of final score
- For a student to pass the course, at least **30%** of the maximum mark from the examination.

Final Grade Distribution Report

2005

Course EE5602 - Active RF & Microwave Technqs

Grade	A+	A	A-	B+	B	B-	C+	C	C-	D	P	F	I	IP	ABS	MNP	NRS	X
% of Students	4.35	13.04	5.80	10.14	23.19	15.94	10.14	8.70	8.70	0.00	0.00	0.00	-	-	-	-	-	-
No. of Students	3	9	4	7	16	11	7	6	6	0	0	0	1	0	0	0	0	0

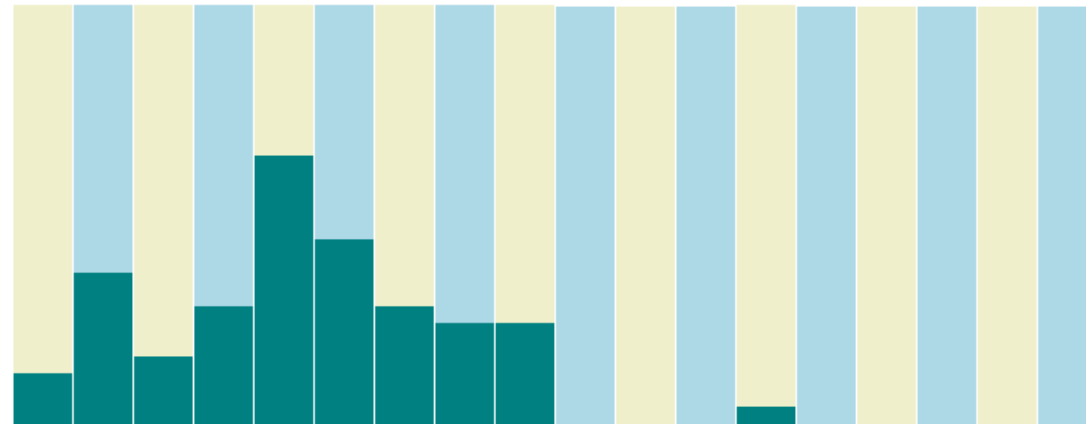

B+ and above
72.4%

Grade	No. of Students	Distribution
A+	3	4.35%
A	9	13.04%
A-	4	5.80%
B+	7	10.14%
B	16	23.19%
B-	11	15.94%
C+	7	10.14%
C	6	8.70%
C-	6	8.70%
D	0	0.00%
P	0	0.00%
F	0	0.00%
Total:	69	

Final Grade Distribution Report

2006

Semester B 2005/06

Final Grade Distribution Report

Course EE5602 - Active RF & Microwave Technqs

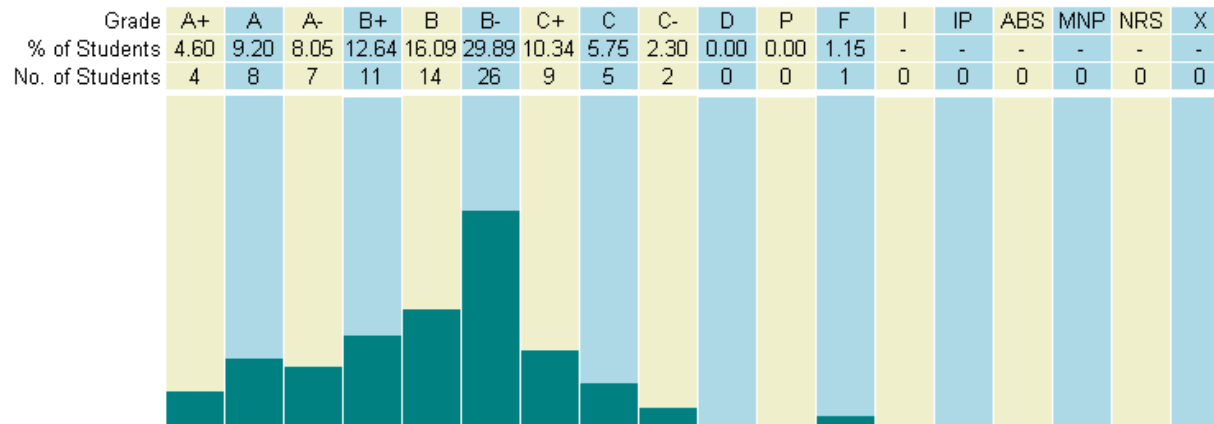

B- and above
51.7%

Grade	No. of Students	Distribution
A+	4	4.60%
A	8	9.20%
A-	7	8.05%
B+	11	12.64%
B	14	16.09%
B-	26	29.89%
C+	9	10.34%
C	5	5.75%
C-	2	2.30%
D	0	0.00%
P	0	0.00%
F	1	1.15%
Total: 87		

Final Grade Distribution Report

2007

Semester B 2006/07

Final Grade Distribution Report

Course EE5602 - Active RF & Microwave Technqs

Grade	A+	A	A-	B+	B	B-	C+	C	C-	D	P	F	I	IP	AB	SM	NP	NR	S	X
% of Students	3.37	3.37	7.87	11.24	13.48	26.97	20.22	12.36	1.12	0.00	0.00	0.00	-	-	-	-	-	-	-	-
No. of Students	3	3	7	10	12	24	18	11	1	0	0	0	0	0	0	0	0	0	1	0

B- and above
66.3%

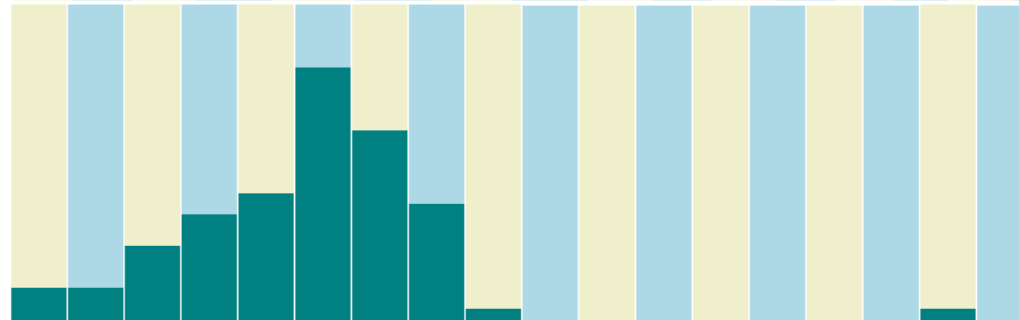

Grade	No. of Students	Distribution
A+	3	3.37%
A	3	3.37%
A-	7	7.87%
B+	10	11.24%
B	12	13.48%
B-	24	26.97%
C+	18	20.22%
C	11	12.36%
C-	1	1.12%
D	0	0.00%
P	0	0.00%
F	0	0.00%

Total: 89

Final Grade Distribution Report

2008

Semester B 2007/08

Final Grade Distribution Report

Course EE5602 - Active RF & Microwave Technqs

B- and above
89.5%

Grade	A+	A	A-	B+	B	B-	C+	C	C-	D	P	F	I	IP	AB	S	M	N	P	N	R	S	X
% of Students	4.48	5.97	10.45	19.40	16.42	17.91	10.45	11.94	2.99	0.00	0.00	0.00	-	-	-	-	-	-	-	-	-	-	-
No. of Students	3	4	7	13	11	12	7	8	2	0	0	0	0	0	0	0	0	0	0	0	0	0	1

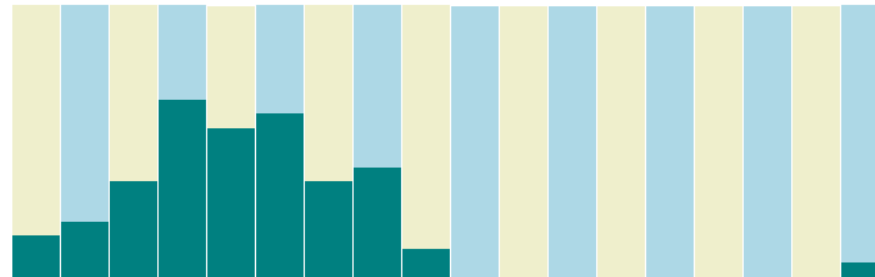

Grade	No. of Students	Distribution
A+	3	4.48%
A	4	5.97%
A-	7	10.45%
B+	13	19.40%
B	11	16.42%
B-	12	17.91%
C+	7	10.45%
C	8	11.94%
C-	2	2.99%
D	0	0.00%
P	0	0.00%
F	0	0.00%

Reference Books

Essential Reading

- Mathew M Radmanesh: Radio Frequency and Microwave Electronics, (Prentice Hall, 2001)
- Reinhold Lidwig and Pavel Bretchiko: RF Circuit Design - Theory and Applications, (Prentice Hall, New Jersey, 2000)

Supplementary Reading

- S Y Liao: Microwave Devices and Circuits, (Prentice Hall, New Jersey, 3rd Edition, 1990)
- David Pozar: Microwave Engineering, (Addison Wesley, New York, 2nd Edition, 1990)
- E H Fooks and R A Zakarevicius: Microwave Engineering Using Microstrip Circuits, (Prentice Hall, New York, 1990)
- R E Collin: Field Theory of Guided Waves, (IEEE Press, New York, 2nd Edition, 1991)
- Robert S Elliott: An Introduction to Guided Waves and Microwave Circuits, (Prentice Hall, New York, 1993)