

Student: Waqas Mahmood
Supervisor: Dr. Leanne Chan

Programme: BENG3-ECE
Co-supervisor: Prof. Henry Chung

Objectives

- To safely transmit 100 mW power for biomedical application between the transmitter and receiver
- To generate magnetic flux in the vicinity of the transmitter which should not exceed $27 \mu T$

Methodology

- Implement analytical equations by MATLAB
- Verification by Finite Element Simulation (COMSOL Multiphysics)
- Experimental verification by developing a prototype

Results

Reference	Transmitter dimensions	Receiver diameter	Receiver's No. of turns	PDL (mW)	Magnetic Flux Density under safety range
[1]	10 x 20 cm	0.5 cm	20	3.9	-
[2]	29 x 20 cm	1.9 cm	19.5 x 4	43	-
[3]	50 x 60 cm	4 cm	2	20	-
[4]	30 x 30 cm	1.05 cm	8	80	-
[5]	103 x 90 cm	2.5 cm	3	20	-
[6]	8 x 8 cm	1.2 cm	-	1.7	-
[7]	27 x 27 cm	4.2 cm	8	120	-
This Work	40 cm (diameter)	3.86 cm	9	100	Yes

- [1] A Smart Cage With Uniform Wireless Power Distribution in 3D for Enabling Long-Term Experiments With Freely Moving Animals, 2009
- [2] Columnar Transmitter based Wireless Power Delivery System for Implantable Device in Freely Moving Animals, 2013
- [3] Towards a Smart Experimental Arena for Long-Term Electrophysiology Experiments, 2012
- [4] A Smart Multicoil Inductively Coupled Array for Wireless Power Transmission, 2014
- [5] A Smart Cage for Behavioral Experiments on Small Freely Behaving Animal Subjects, 2013
- [6] A system for wireless power transfer of micro-systems in-vivo implantable, 2014
- [7] A Smart Cage With Uniform Wireless Power Distribution in 3D for Enabling Long-Term Experiments With Freely Moving Animals, 2015

Conclusion

- Based on the result in Fig 7, we can confirm that a Helmholtz coil with a transmitter radius of 20 cm and a separation of 10 cm is the best model for safely transmitting wireless power of 100 mW to the receiver.
- It is also one of the first coil configuration study considering the safety limit of magnetic flux density

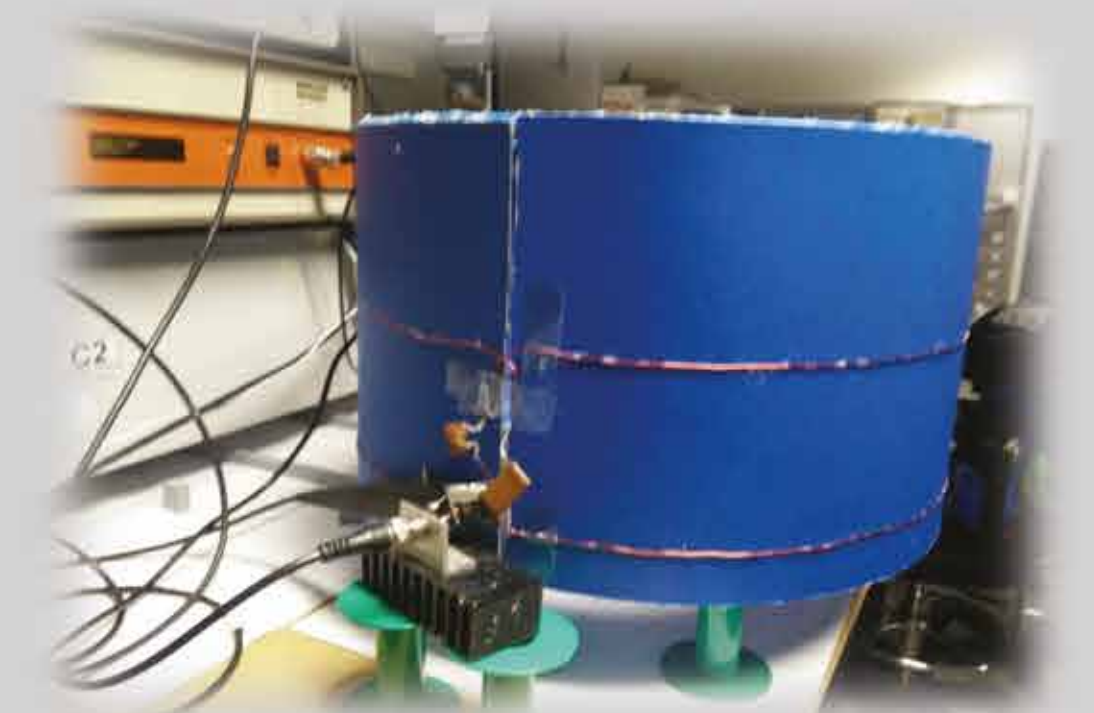

Fig 1: Transmitter

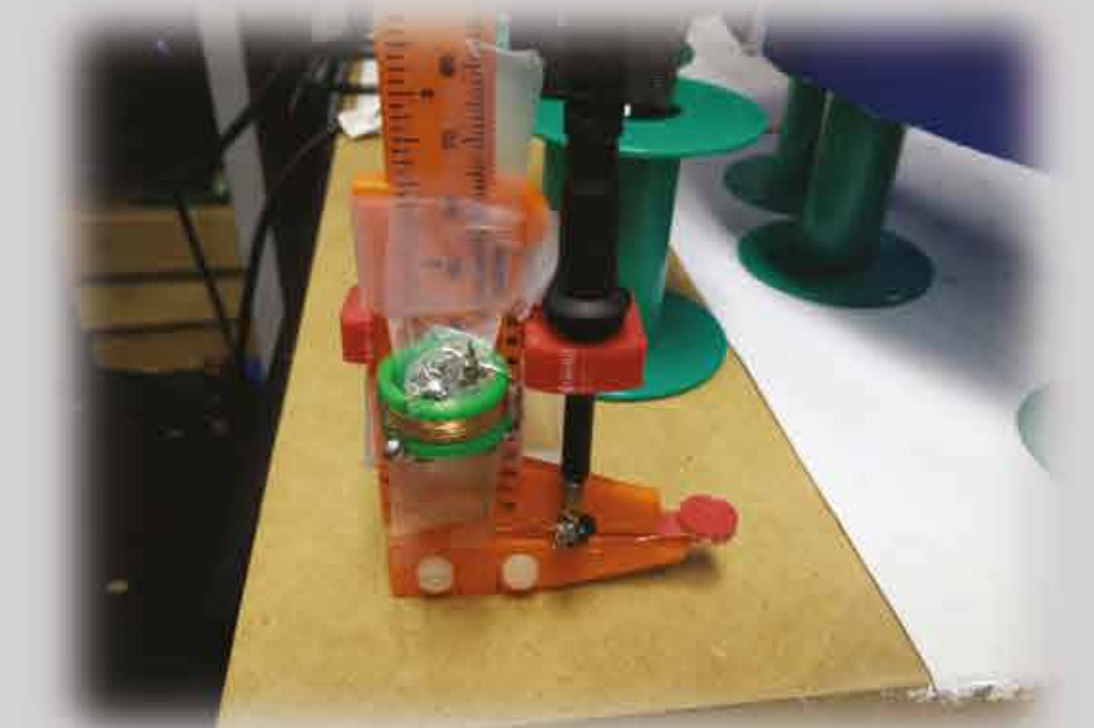

Fig 2: Receiver

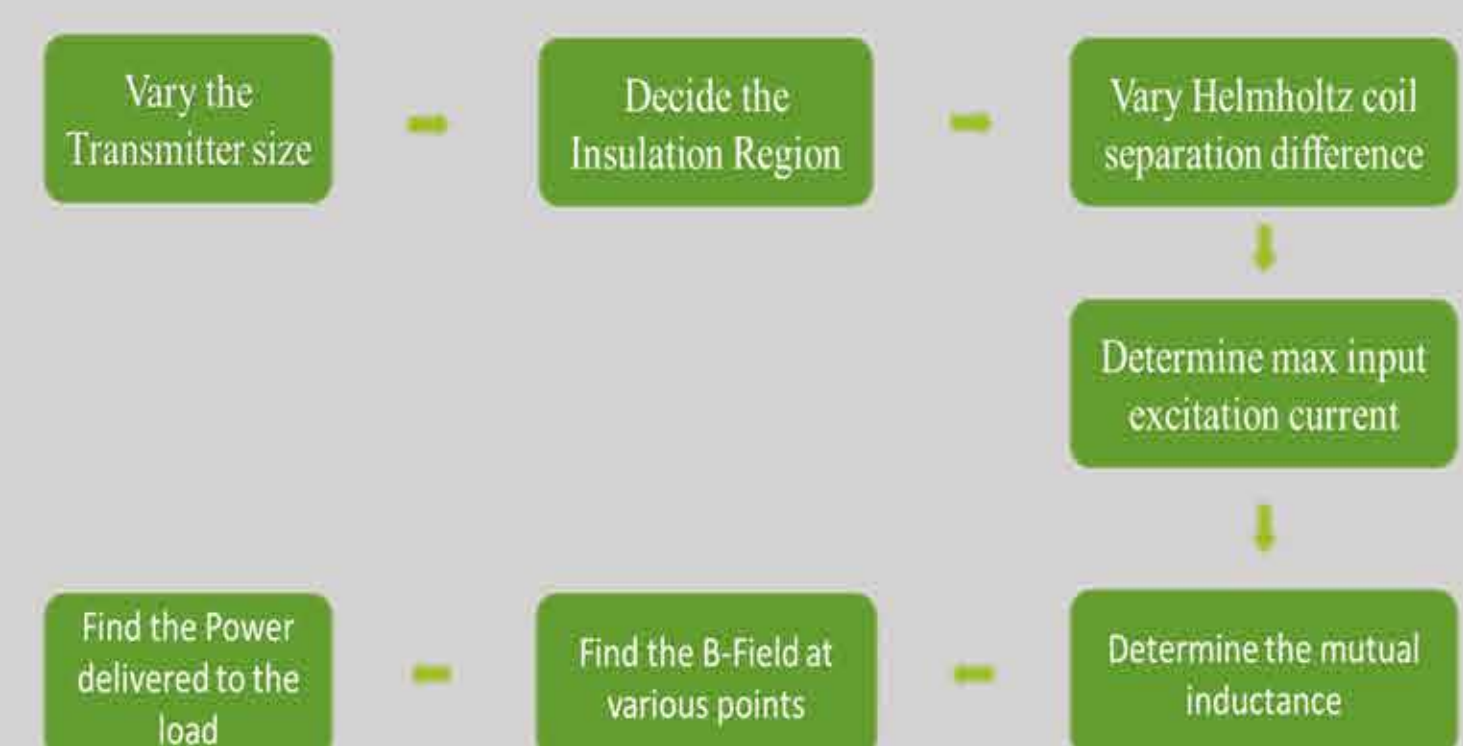

Fig 3: Flowchart showing design and optimization

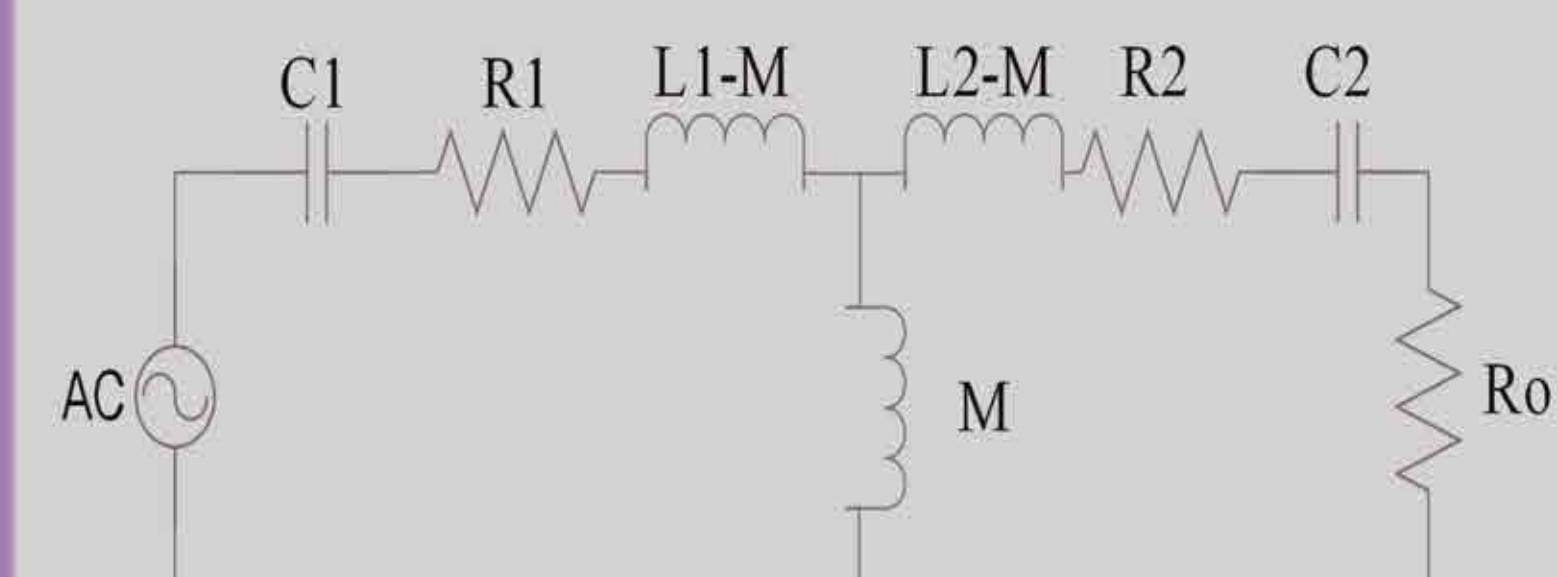

Fig 4: Circuit Diagram

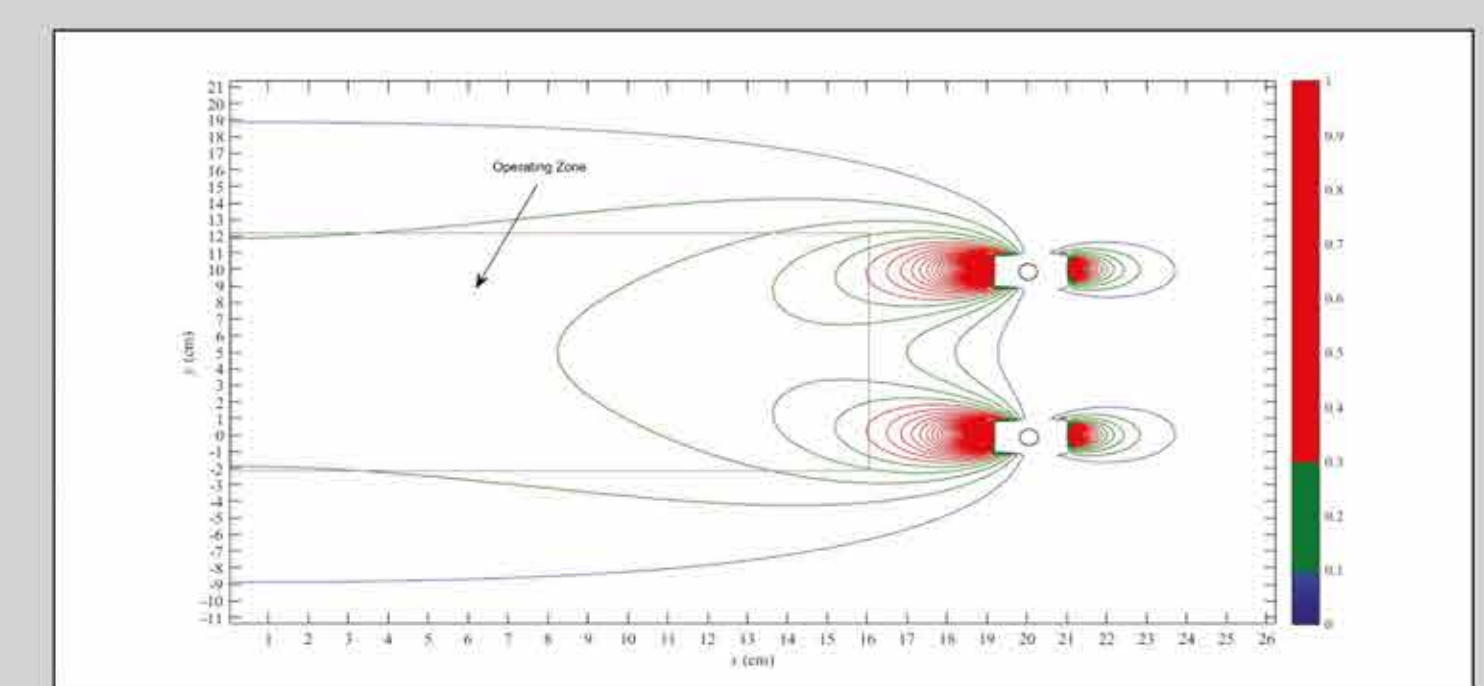

Fig 5: Power distribution (MATLAB)

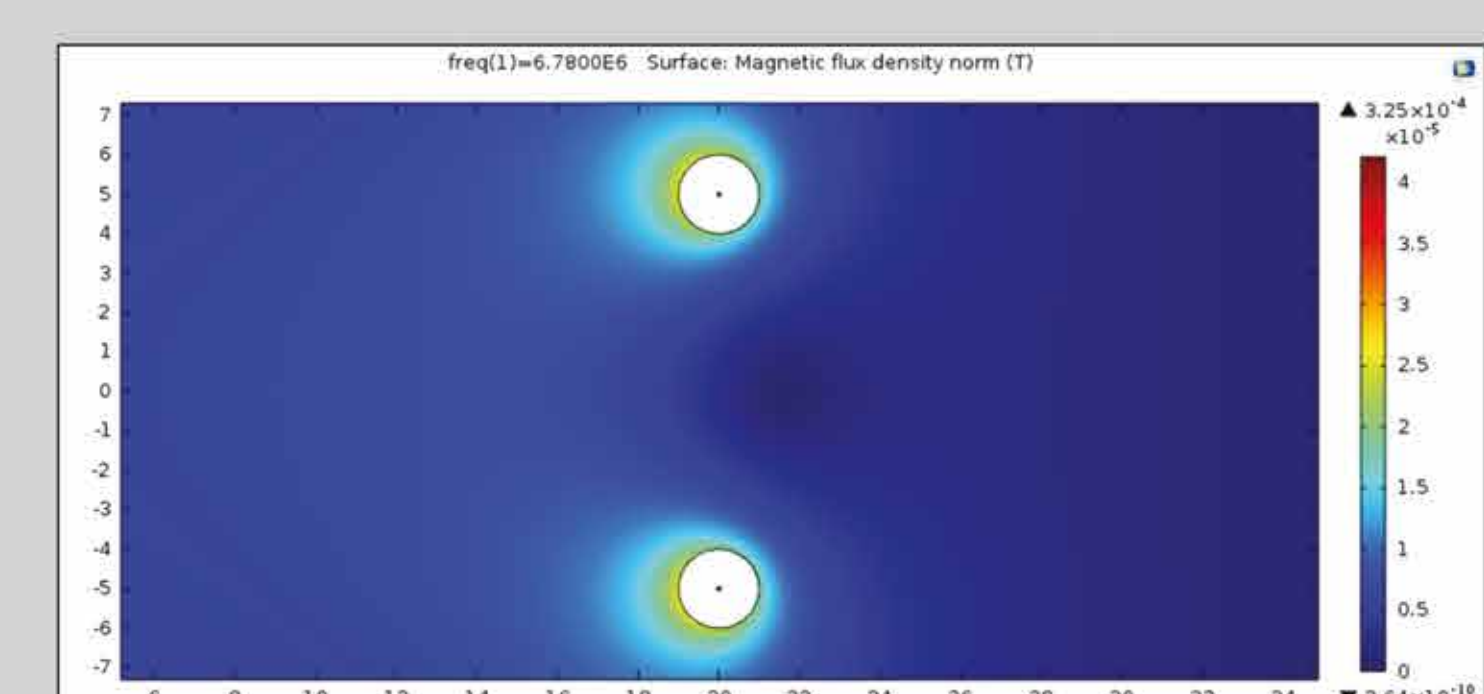

Fig 6: Magnetic flux distribution (COMSOL)

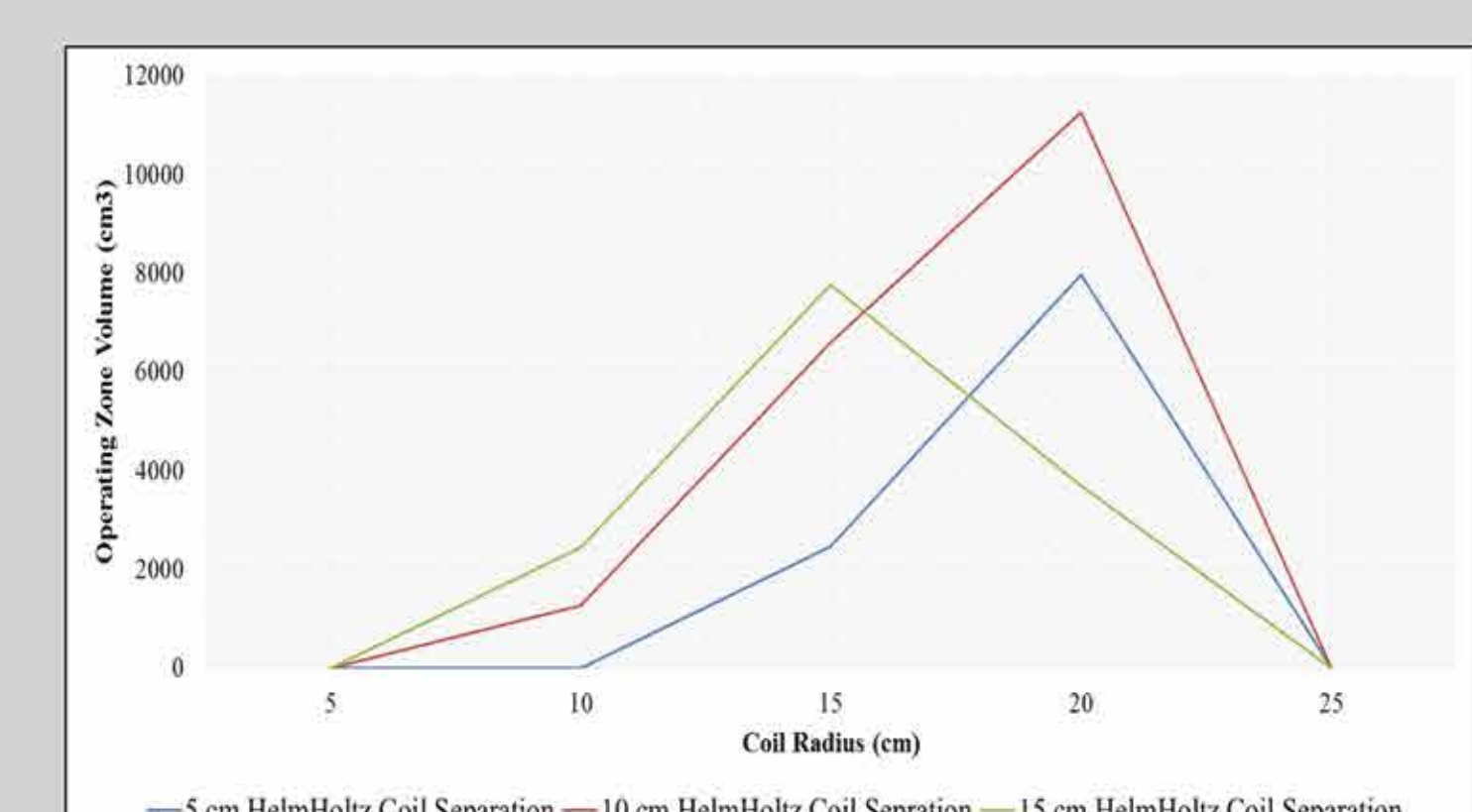

Fig 7: Operating zone volume for different configurations