



Short Course on Wireless Power Transfer Technologies



CityU

香港城市大學
City University of Hong Kong

Part V: Control and Other Issues

C K MICHAEL TSE

Department of Electrical Engineering

City University of Hong Kong

<http://www.ee.cityu.edu.hk/~chitse>



CONTROL AND OTHER ISSUES

PART V

Control Strategy

- Basic Control
 - Frequency control - changing operating frequency
 - Fixed frequency PWM control - changing fundamental magnitude
 - Phase locked loop control
- System Control
 - Phase-locked loop control and downstream dc-dc converter control
 - Phase-locked loop control and phase-shift PWM control
 - Primary side combined control

Basic Control Strategy

Frequency control is the basic method for IPT systems as it varies the frequency to directly adjust the output voltage or current according to the resonant characteristic.

Disadvantages:

- ☹️ Not suitable for varying loads and varying coupling coefficient.
- ☹️ In the region of monotonic variation of the output voltage, the voltage gain is quite low, and the frequency is high.

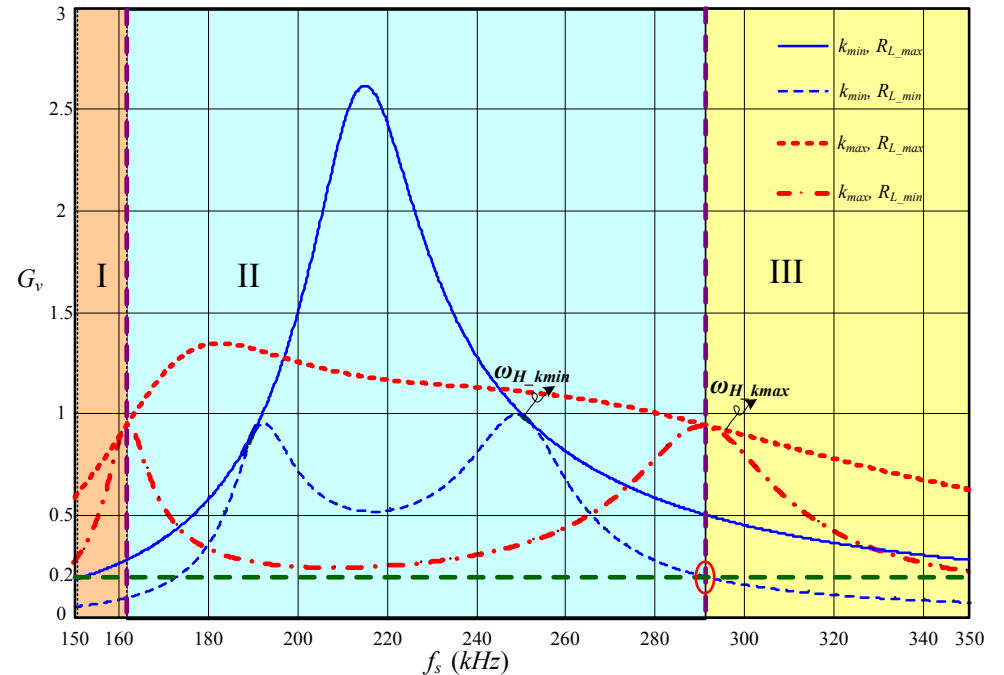

Basic Control Strategy

Fixed frequency PWM control is another basic method for IPT systems as it varies the duty cycle of the input voltage to directly adjust the amplitude of the input voltage, and hence the output voltage.

Disadvantage:

☹️ At small duty cycle, the soft switching condition can be violated, affecting the efficiency of the system.

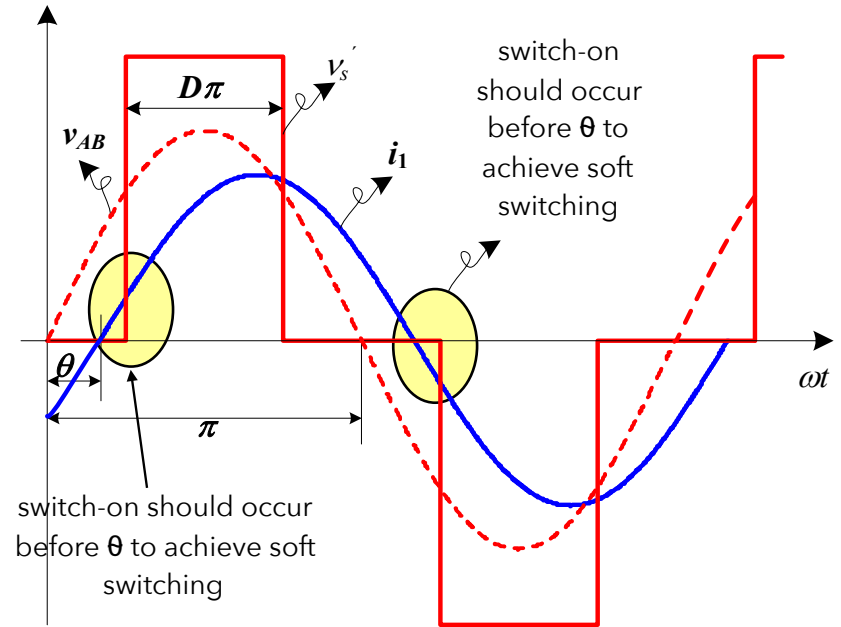

Phase-locked Loop Control

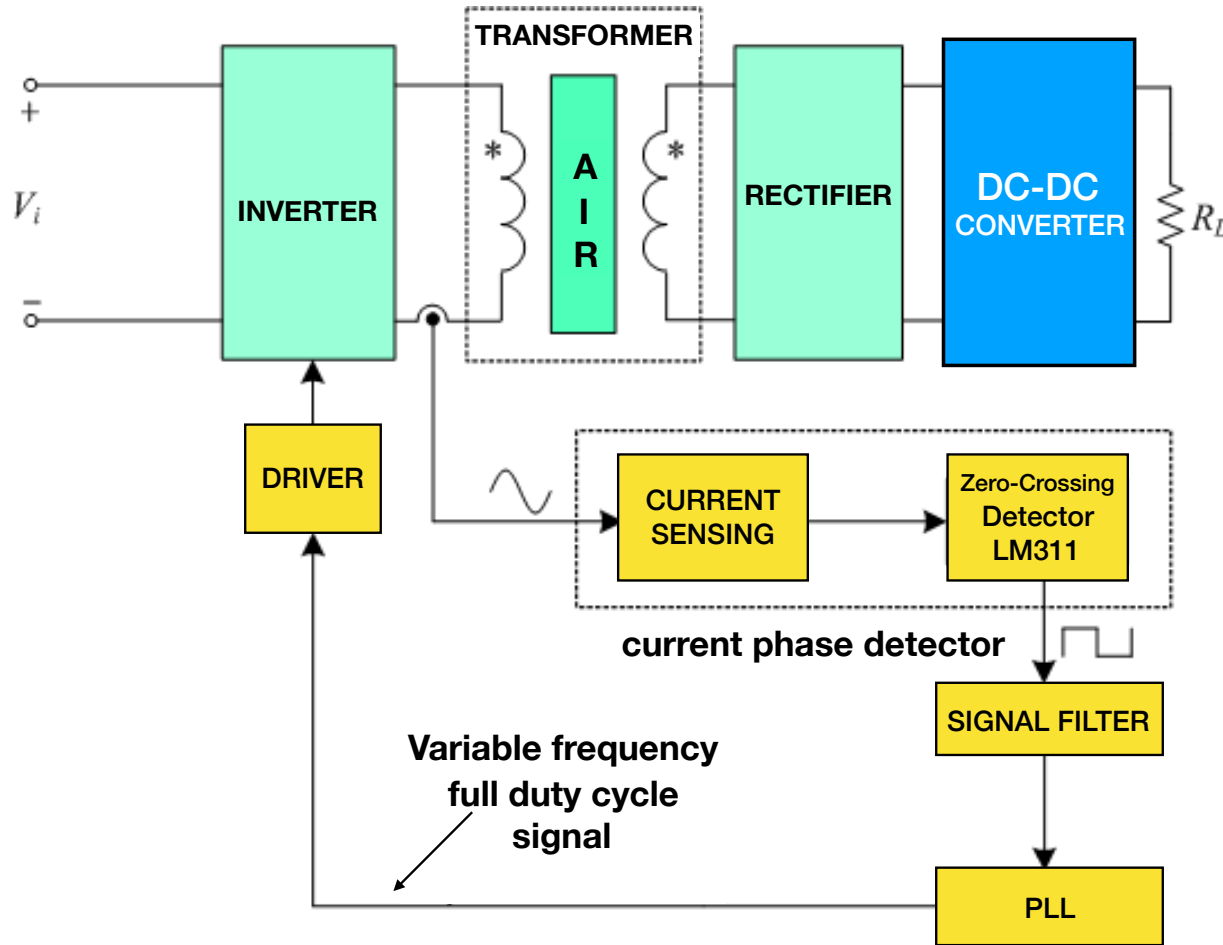

Advantage:

😊 Using PLL control, the converter can be ascertained to work under soft switching conditions, maintaining good efficiency.

Disadvantage:

😞 Imprecise control of frequency leads to imprecise output voltage or current control. Thus, an additional stage is often needed.

😞 Under light load or low coupling condition, the PLL frequency range may not reach the required output voltage.

Primary-side PLL control

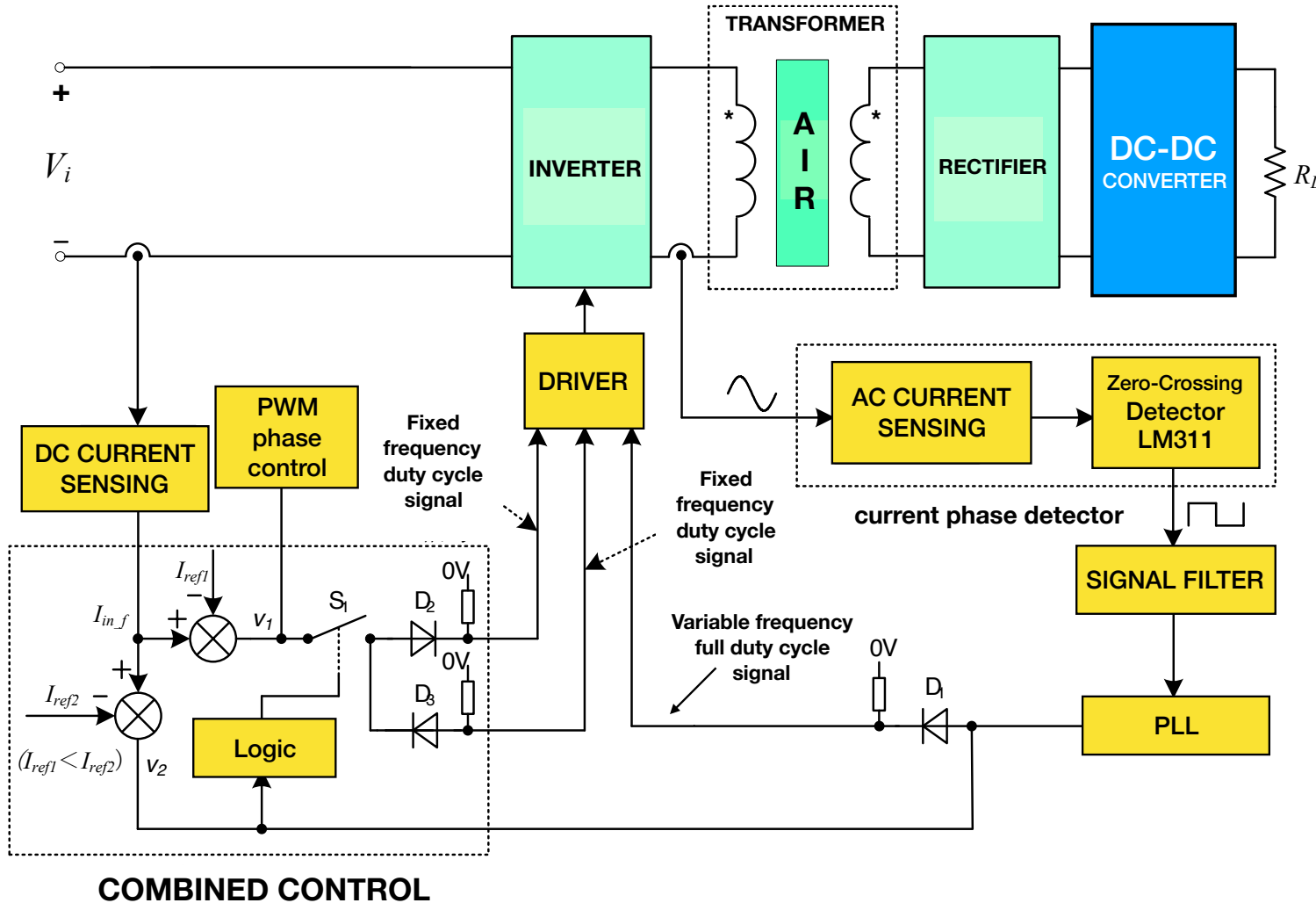

At light load, fixed frequency and low duty cycle are used. The duty cycle equals the preset value at end of soft start. This is just enough to give a low magnitude at fundamental frequency, hence giving low output voltage.

For heavier load, phase shift PWM is used. The duty cycle increases according to the load linearly, and eventually to normal or full load under the PLL control with full duty cycle.

Primary-side Self-oscillating Control

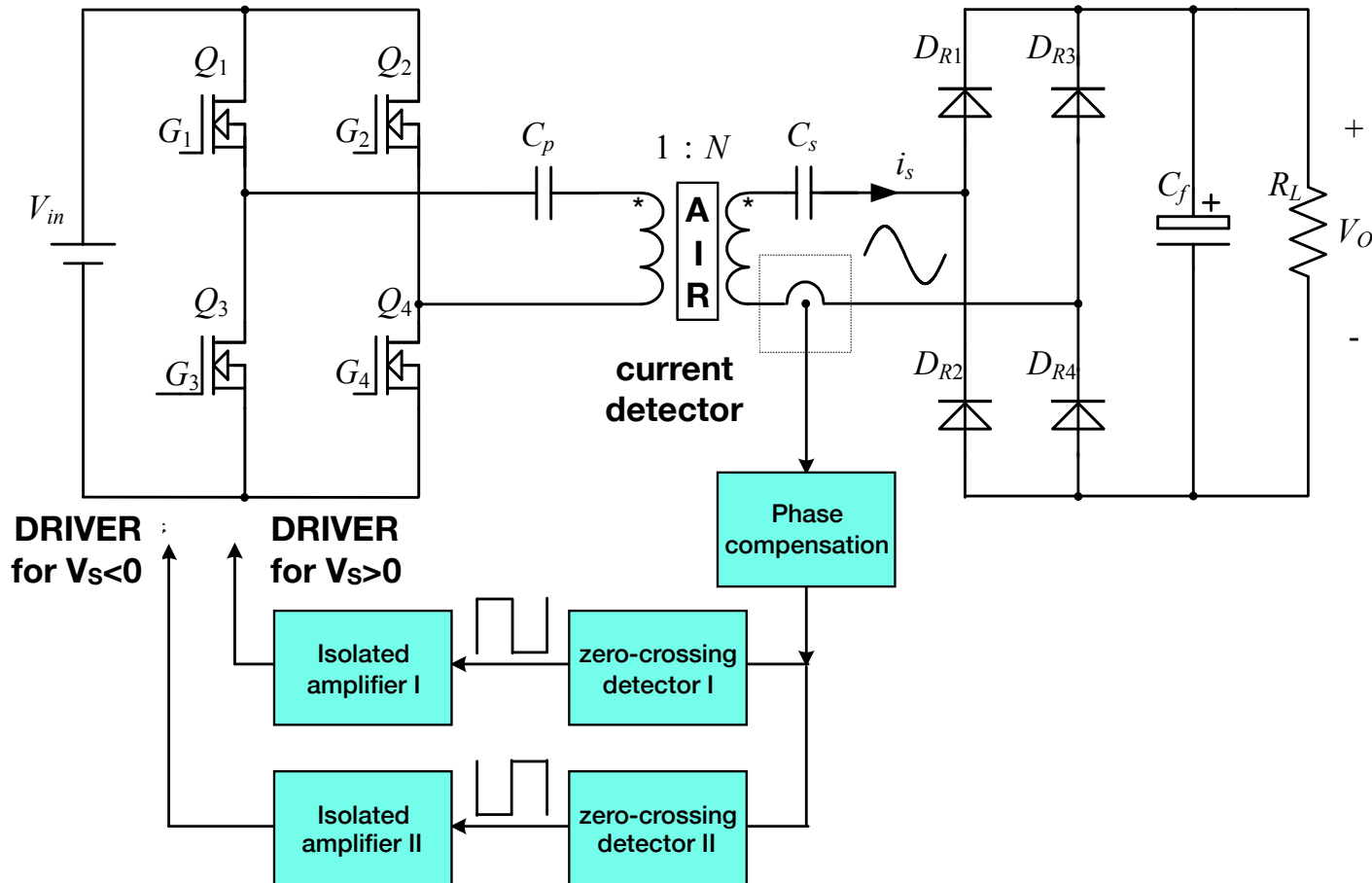

Advantages:

- 😊 Simple.
- 😊 Soft switching, high efficiency.
- 😊 Adaptive to air gap and load variations
- 😊 Fast transient response

Disadvantages:

- 😞 Relatively large overshoot during transient.

Self-Oscillating Resonant Converter With Contactless Power Transfer and Integrated Current Sensing Transformer

Ligang Xu, *Student Member, IEEE*, Qianhong Chen, *Member, IEEE*, Xiaoyong Ren, *Member, IEEE*,
Stu-Chung Wong, *Senior Member, IEEE*, and Chi K. Tse, *Fellow, IEEE*

Abstract—In this paper, an integrated transformer is proposed to provide current sensing in the primary side and passive current phase detection for a self-oscillating contactless resonant converter (SOCRC). The proposed transformer integrates power transfer and current sensing. By using the secondary current phase of a series/series-compensated resonant converter in the control of the inverter, better output controllability, dynamic response, and self-adaptability can be achieved simultaneously. The integrated current sensing winding, being a crucial part of SOCRC, is analyzed in detail. In order to make the output voltage insensitive to the clearance and misalignment conditions, the requirement of the new integrated transformer is given. Experimental results of an 80-W SOCRC prototype verify the analytical results.

Index Terms—Inductive power transfer (IPT), magnetic integration, self-oscillating resonant converter, transformer, wireless power transfer.

I. INTRODUCTION

AN inductive power transfer (IPT) system transfers power from one circuit to another through electromagnetic induction without any physical contact. It has been used in various applications ranging from a few milliwatts in biomedical applications up to several kilowatts of output power in automotive applications [1]–[4]. Due to its convenience and safety against electric shock, IPT has become increasingly popular in home appliances, mobile devices, industrial sensors, and electric vehicle (EV) chargers [5]–[7].

Although IPT systems have unique advantages in some specific applications, due to the loosely coupled transformer, the performance of an IPT system is still far from being optimal,

Manuscript received March 26, 2016; accepted July 22, 2016. Date of publication August 8, 2016; date of current version February 11, 2017. This work was supported in part by Lite-On Power Electronics Technology Research Fund, in part by the National Natural Science Foundation of China under Grant named Theory and Key Technology Research of Redundant Contactless Electronics Slip Ring Based on the Motor-slip Analog, and in part by the National Natural Science Foundation of China under Grant 51377081. Recommended for publication by Associate Editor M. Duffy.

L. Xu, Q. Chen, and X. Ren are with the Jiangsu Key Laboratory of New Energy Generation and Power Conversion, Nanjing University of Aeronautics and Astronautics, Nanjing 210016, China (e-mail: xlg324@163.com; chenqh@nuaa.edu.cn; renxy@nuaa.edu.cn).

S.-C. Wong and C. K. Tse are with the Department of Electronic and Information Engineering, The Hong Kong Polytechnic University, Kowloon, Hong Kong (e-mail: enscwong@polyu.edu.hk; michael.tse@polyu.edu.hk).

Color versions of one or more of the figures in this paper are available online at <http://ieeexplore.ieee.org>.

Digital Object Identifier 10.1109/TPEL.2016.2598556

0885-8993 © 2016 IEEE. Personal use is permitted, but republication/redistribution requires IEEE permission. See http://www.ieee.org/publications_standards/publications/rights/index.html for more information.

compared to conventional power transfer systems. Moreover, the parameters of the transformer change greatly due to the need for necessary clearances and possible misalignments, leading to variation of the output performance. Therefore, the design and optimization of the IPT system under parameter variations have become an important research topic.

A great deal of research has been devoted to improve the performance of IPT systems, including coupling optimization [2], compensation method [9], [10], impedance matching [11], frequency tracking [12], [13], power flow control [14]–[16], dc/dc conversion [17], [18], etc. In [9] and [10], the series/series-parallel and series-parallel/series topologies are proposed to make the output voltage insensitive to coupling variation, respectively. In [11], a novel control method is presented to regulate the power transfer by tuning the effective resonant capacitance. In [12], a parallel-resonant Class-D oscillator is proposed, which can track the split resonant frequency automatically, so as to achieve a constant output voltage. Pulse-width-modulation phase-locked-loop control strategy is proposed in [13] to achieve output voltage control and zero-voltage switching (ZVS) at the same time. In [14], a primary side feedback method for an IPT system is proposed, using a feedback method to deal with impedance variations in the primary side when the charging path on the secondary side is being switched ON and OFF. In some specific applications, fluctuation of the load or the coupling necessitates the use of some power flow control technique, which can be implemented on either the primary or secondary side. In [15], the received power on the secondary side can be regulated by tuning or detuning the pickup on the secondary side to regulate the output power and voltage. For IPT systems with a single pickup, it is preferable to control the power flow on the primary side of the system because of the size, weight, and heat constraints [16]. To regulate the output voltage for an IPT system under parameter variations, the use of a dc/dc converter in the transmitting or receiving side is also a simple and effective approach.

Although a number of power or output voltage control strategies have been proposed, effective methods to improve the dynamic performance for IPT systems are still lacking. For some special applications, such as power supplies for CPUs and implantable devices [12], the dynamic performance is also an important consideration. Self-oscillating control is a control strategy that can achieve better dynamic response and

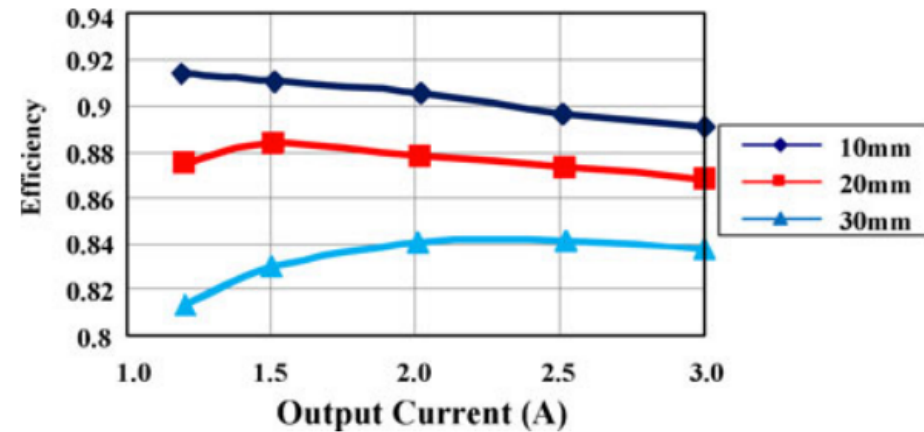
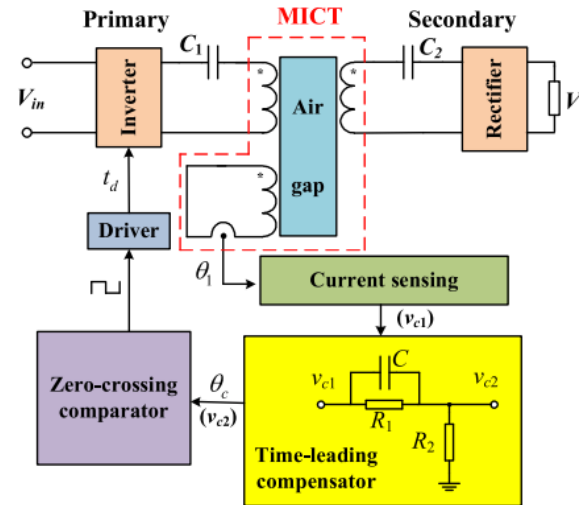

Control Design for Max Efficiency

Control Design for Optimizing Efficiency in Inductive Power Transfer Systems

Zhichong Huang, Student Member, IEEE, Siu-Chung Wong, Senior Member, IEEE, and Chi K. Tse, Fellow, IEEE

Abstract—Inductive power transfer (IPT) converters are resonant converters that attain optimal energy efficiencies for a certain load range. To achieve maximum efficiency, it is common to cascade the IPT converter with front-side and load-side dc/dc converters. The two dc/dc converters are normally controlled cooperatively for the requirements of output regulation and maximum efficiency tracking using a control technique based on perturbation and observation, which is inevitably slow in response. In this paper, a decoupled control technique is developed. The load-side dc/dc converter is solely responsible for output regulation, while the front-side converter is responsible for impedance-matching of the IPT converter by controlling its input-to-output voltage ratio. The controls are linear and therefore fast. DC and small-signal transfer functions are derived for designing the control parameters. The performances of fast regulation and high efficiency of the IPT converter system are verified using a prototype system.

Index Terms—Control for maximum efficiency, inductive power transfer (IPT), wireless power transfer.

I. INTRODUCTION

DESIGN and optimization of inductive power transfer (IPT) systems have been widely studied. One of the main objectives is to achieve high efficiency. The optimization involves the choice of appropriate structure of magnetic couplers [1] and their interoperability [2]. It is well known that a higher coupling coefficient and higher coil quality factors of the pair of windings of the magnetic coupler would increase the system efficiency [3]. [4]. Optimization approaches for these two parameters to achieve high efficiency have been proposed [5], [6]. Meanwhile, since the system efficiency is not monotonically varying with the load, optimum loads that achieve maximum efficiency of the system are also studied [7]–[9]. Moreover, various design aspects to achieve maximum efficiency for different converter input–output transfer functions using series and parallel compensations have been studied [10], [11]. Previous studies show that given a coupling coefficient and coil quality factors, an IPT converter should be designed to operate at

some fixed operating frequencies with load-independent transfer characteristic and slight modulation for soft switching when a simple half-bridge or full-bridge inverter circuit is used, and to operate within a restricted load range in order to achieve maximum efficiency [10]–[13]. Among the four basic types of compensation, the widely used series-series compensated IPT (SSIPT) converter is the most power efficient IPT converter when it is operating with load-independent output current [7]–[13]. However, in some practical applications, the design may not meet the required wide variations of the coupling coefficient, the load resistance, and the load power. Thus, once an IPT converter has been designed at a particular coupling coefficient and a particular load, the efficiency of the IPT system cannot always be maintained near its maximum point.

To improve the system efficiency under variation of the load, a load-side dc/dc converter is connected between the load and the secondary of an SS IPT converter to adaptively control the equivalent load observed by the SS IPT converter, thus maintaining a maximum efficiency of the front-end power amplifier driver [14], [15]. To achieve output regulation, source modulation is needed. The modulation can be provided by either a pulse width modulated inverter, a front-side dc/dc converter which amplitude modulates the inverter circuit, or a power amplifier. The inverter circuit is mostly implemented by either a half-bridge or full-bridge circuit, which provides the highest efficiency but suffers from shallow modulation due to the need for maintaining soft switching [9]–[11]. The depth of modulation can be greatly improved when the inverter is amplitude modulated by a front-end dc/dc converter. The combined circuit incurs a penalty of additional loss due to the extra power stage. The power amplifier can be considered as a circuit consisting of a front-side dc/dc converter, amplitude modulating an inverter circuit, with an output filter. The study by Li *et al.* [16] shows that a system consisting of an SS IPT converter with front-side and load-side dc/dc converters (the system is denoted as F-SSIPT-L) can achieve better overall system efficiency compared to a system consisting of the same SS IPT converter and a load-side dc/dc converter utilizing the modulation of the internal inverter (such a system is denoted as M-SSIPT-L) with frequency modulation. A maximum efficiency tracking (MET) algorithm has been proposed by Li *et al.* [16], where the secondary dc/dc converter regulates the output voltage while the front-side dc/dc converter maximizes the system efficiency. Another MET algorithm has also been studied using the F-SSIPT-L system where the front-side dc/dc converter controls the input current of the SS IPT converter for better handling of small coupling

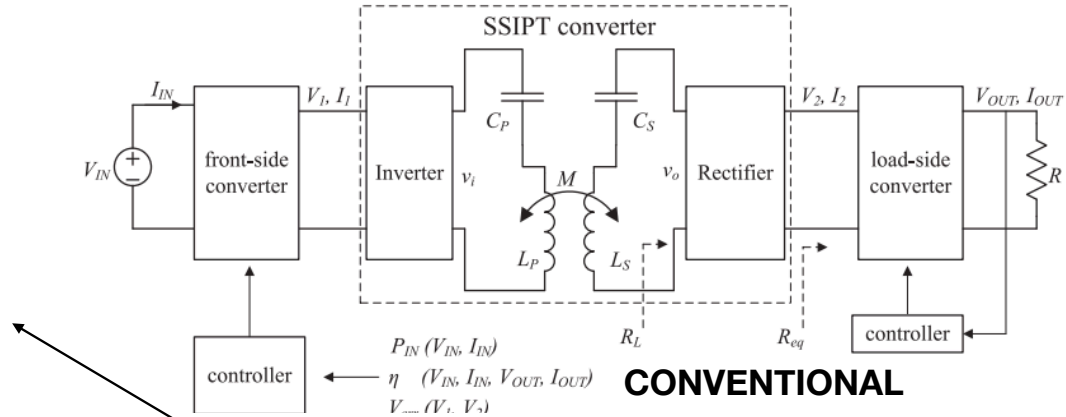

TABLE I
COMPARISON OF DIFFERENT CONTROL SCHEMES

Control function	V_{err} , voltage error control (this paper)	η , maximum efficiency tracking [16], [17]	P_{IN} , minimum input power tracking [18]
Monotonicity	$\frac{\Delta V_{err}}{\Delta m_1}$ is always positive	probing $\frac{\Delta \eta}{\Delta m_1}$ for signs	probing $\frac{\Delta P_{IN}}{\Delta m_1}$ for signs
Control reference	$V_{err,ref} = 0$	adaptively tracking the maximum point.	adaptively tracking the minimum point.
Control method	PI controller, analog or digital	P&O, digital	P&O, digital
Sampling	V_1, V_2	$V_{IN}, I_{IN}, V_{OUT}, I_{OUT}$	V_{IN}, I_{IN}

Manuscript received December 9, 2016; revised April 3, 2017 and May 25, 2017; accepted June 27, 2017. Date of publication July 7, 2017; date of current version February 1, 2018. This work was supported by Hong Kong Polytechnic University under Central Research Grant G-YBKC. Recommended for publication by Associate Editor C. T. Rim. (Corresponding author: S.-C. Wong.)

The authors are with the Department of Electronic and Information Engineering, The Hong Kong Polytechnic University, Kowloon, Hong Kong (e-mail: zhichong.huang@connect.polyu.hk; ensicwong@polyu.edu.hk; enckit@polyu.edu.hk).

Color versions of one or more of the figures in this paper are available online at <http://ieeexplore.ieee.org>.
Digital Object Identifier 10.1109/TPEL.2017.2724039

Decoupled Control Design

Efficiency is optimized at a particular load for the SS IPT.

The transconductance at max efficiency:

$$|G| = \left| \frac{i_o}{v_i} \right| = \frac{\omega M}{R_P(R_S + R_L) + \omega^2 M^2}$$

Voltage ratio of SS IPT at max efficiency:

$$|H| = \left| \frac{v_o}{v_i} \right| = |G| R_{L,opt} \approx \sqrt{\frac{R_S}{R_P}}$$

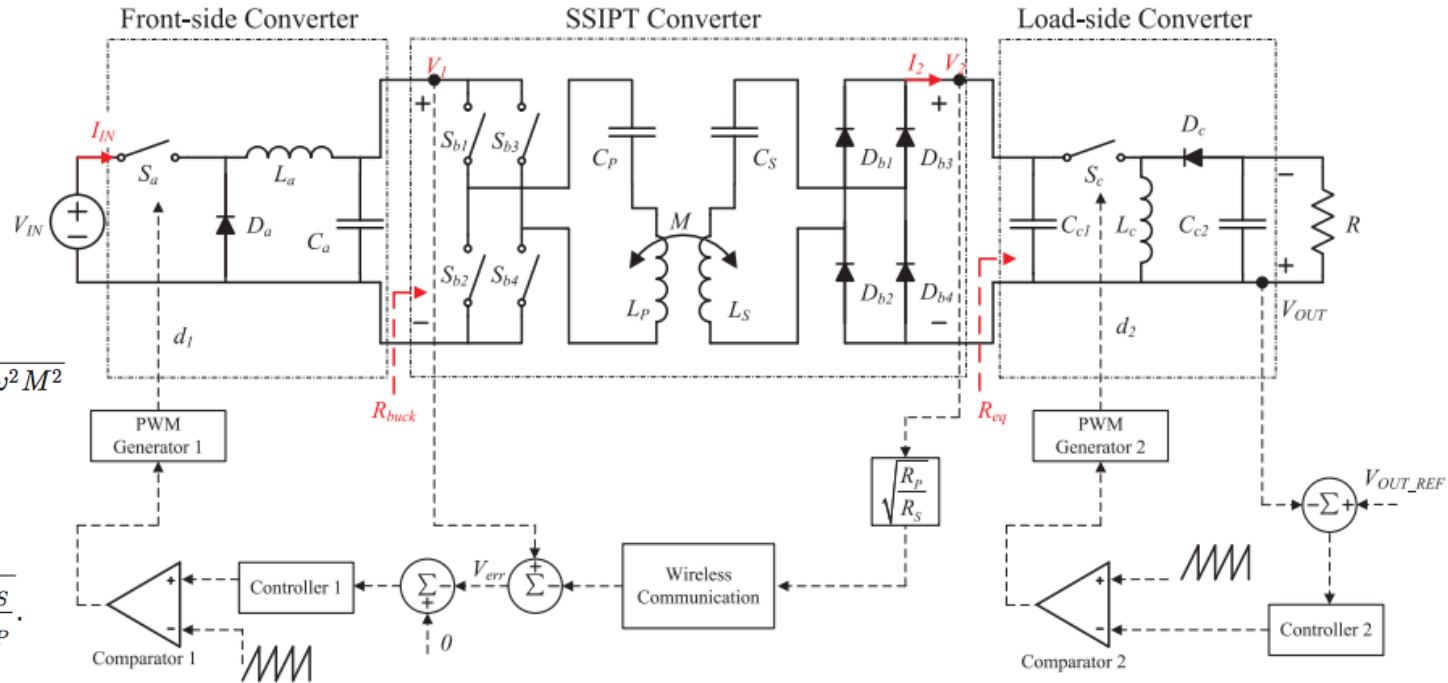

The load-side dc/dc converter is solely responsible for output regulation, while the front-side converter is responsible for impedance-matching of the IPT converter by controlling its input-to-output voltage ratio. The controls are linear and therefore fast.

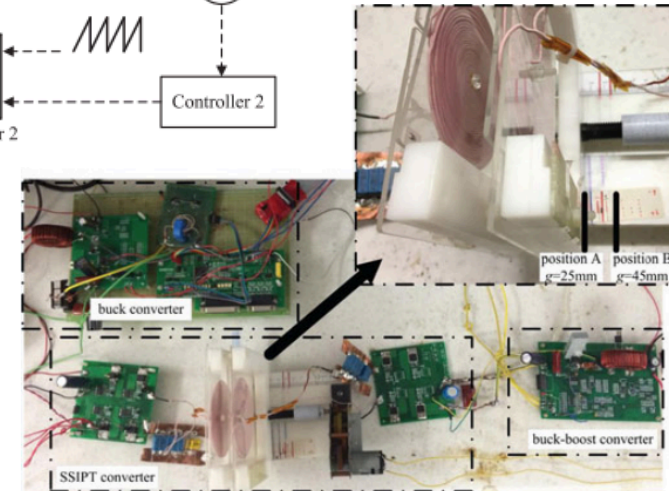

Design Example 1

Series-series Compensated IPT Converter

Specification:

DC Input: 30 V

DC Output: 24 V

Output Power: 12 ~ 60 W

Gap: 10 ~ 20 mm

Basic calculation:

Transformer turns ratio:

$$n = 24/30 = 0.8$$

Considering the actual resistance voltage drop, the physical turns can be $n = 17 : 19$.

Then, we decide the Q factor range. Usually we limit $Q_{\max} < 10$ to limit the voltage stress on the compensation capacitor.

$$\frac{Q_{\max}}{Q_{\min}} = \frac{P_{o_max}}{P_{o_min}} = \frac{60}{12} = 5$$

Take $Q_{\max} = 7.5; Q_{\min} = 1.5$

Transformer Design:

According to the air gap width and size, the transformer should be designed to maximize coupling.

Choices:

- Type of core (E core)
- Material grade (3C30, 3F3, ...)

Design Example 1

Series-series Compensated IPT Converter

E-core 64/10/50; Ferrite grade 3F3

TRANSFORMER PARAMETERS	Gap = 10 mm	Gap = 20 mm
Primary Self-inductance L_p	52.93 μH	45.32 μH
Secondary Self-inductance L_s	44.14 μH	39.31 μH
Primary Leakage Inductance L_{L1}	22.17 μH	31.37 μH
Secondary Leakage Inductance L_{L2}	19.52 μH	28.14 μH
Magnetizing Inductance L_M	30.76 μH	13.95 μH
Coupling Coefficient k	0.569	0.296



PRIMARY



SECONDARY

CORE SELECTION

Ferroxcube
Soft ferrites and
accessories

Core material grade:
Frequency of operation

<https://ptelectronics.ru/wp-content/uploads/Obshchii-katalog-FERROXCUBE.pdf>

Soft Ferrites

FERRITE SELECTION

Dependent on the converter type, the ferrites used in these converters operate under saturation or loss limited conditions, which require special power ferrites with high saturation and low loss levels even at elevated operation temperatures.

The operating frequency is one of the parameters defining which core material can be used in an application. For

those SMPSs which are connected directly to a high input voltage (e.g. the rectified mains can be up to 400 V in some parts of the world), semiconductors with a high breakdown voltage are needed. A high breakdown voltage limits the switching frequency otherwise severe switching losses inside the semiconductor occur (on the other hand, a low voltage device can be used at much higher operating frequencies). For flyback converters things are even worse. When the mosfet is switched off, it's drain-source voltage is the sum of input and rectified secondary voltage. Therefore the operating frequency of a high voltage input SMPS is limited by the capabilities of the used semiconductors and switching frequencies up to 300 kHz can be found nowadays even when the semiconductors are connected to a heatsink. This means that most power ferrites of the 3Cxx series will mainly be used under saturation limited conditions, see also the performance factor graph in Fig.19. On top, for many applications the operating frequency is only a few tens of kHz due to EMC regulations. The reason is that these requirements can relatively easily be met in the frequency area below 150 kHz.

Converters which are not directly connected to a high input voltage and/or soft-switching power supplies, like half and full bridge (resonant) converters can overcome this problem and operating frequencies into the MHz range can be found. Power ferrites for this range are gathered in the 3Fxx series and 4F1.

The energy storage inductor of all converters (except flyback and resonant) normally operates at a bias level, therefore ferrites with a high saturation value at the application temperature, like 3C92, result in the smallest core volumes.

In case of post regulators, the operating frequency can be chosen much higher as the input voltage is much lower and the generated EMI will be sufficiently attenuated by the SMPS in front of the post regulator. Now ferrites from the 3Fxx series and 4F1 are the best choice.

All the inductors, including the coupled inductor of the flyback converter, need an air gap necessary for the energy storage, while the transformers can be made without gap.

Applications

CORE SELECTION

OPERATING FREQUENCY

The preferred operating frequency of a Switched Mode Power Supply is greater than 20 kHz to avoid audible noise from the transformer. With modern power ferrites the practical upper limit has shifted to well over 1 MHz.

Ambient temperature

Ambient temperature, together with the maximum core temperature, determines the maximum temperature rise, which in turn fixes the permissible total power dissipation in the transformer. Normally, a maximum ambient temperature of 60 °C has been assumed. This allows a 40 °C temperature rise from the ambient to the centre of the transformer for a maximum core temperature of 100 °C. There is a tendency however towards higher temperatures to increase power throughput densities. Our new material 3C93 meets these increased temperature requirements with a loss minimum around 140 °C

Flux density

To avoid saturation in the cores the flux density in the minimum cross-section must not exceed the saturation flux density of the material at 100 °C. The allowable total flux is the product of this flux density and the minimum core area and must not be exceeded even under transient conditions, that is, when a load is suddenly applied at the power supply output, and maximum duty factor occurs together with maximum supply voltage. Under steady-state conditions, where maximum duty factor occurs with minimum supply voltage, the flux is reduced from its absolute maximum permissible value by the ratio of the minimum to maximum supply voltage (at all higher supply voltages the voltage control loop reduces the duty factor and keeps the steady-state flux constant).

The minimum to maximum supply voltage ratio is normally taken as 1 : 1.72 for most applications.

Soft Ferrites

SELECTING THE CORRECT CORE TYPE

The choice of a core type for a specific design depends on the design considerations and also on the personal preference of the designer. Table 1 gives an overview of core types as a function of power throughput and this may be useful to the designer for an initial selection.

Each of the core types has been developed for a specific application, therefore they all have advantages and drawbacks depending on, for example, converter type and winding technique.

Table 1 Power throughput for different core types at 100 kHz switching frequency

POWER RANGE (W)	CORE TYPE
< 5	RM4; P11/7; T14; EF13; U10
5 to 10	RM5; P14/8
10 to 20	RM6; E20; P18/11; T23; U15; EFD15
20 to 50	RM8; P22/13; U20; RM10; ETD29; E25; T26/10; EFD20
50 to 100	ETD29; ETD34; EC35; EC41; RM12; P30/19; T26/20; EFD25
100 to 200	ETD34; ETD39; ETD44; EC41; EC52; RM14; P36/22; E30; T58; U25; U30; E42; EFD30
200 to 500	ETD44; ETD49; E55; EC52; E42; P42/29; U67
> 500	E65; EC70; U93; U100; P66/56; PM87; PM114; T140

Choice of ferrite for power transformers and inductors

A complete range of power ferrites is available for any application.

3C30

Low frequency (< 200 kHz) material with improved saturation level. Suitable for flyback converters e.g. Line Output Transformers.

3C34

Medium frequency (< 300 kHz) material with improved saturation level. Suitable for flyback converters e.g. Line Output Transformers.

3C81

Low frequency (< 100 kHz) material with loss minimum around 60 °C.

Applications

3C90

Low frequency (< 200 kHz) material for industrial use.

3C91

Medium frequency (< 300 kHz) material with loss minimum around 60 °C.

3C92

Low frequency (< 200 kHz) material with a very high saturation level. Specially recommended for inductors and output chokes.

3C93

Medium frequency (< 300 kHz) material with loss minimum around 140 °C.

3C94

Medium frequency material (< 300 kHz). Low losses, especially at high flux densities.

3C96

Medium frequency (< 400 kHz) material. Very low losses, especially at high flux densities.

3F3

High frequency material (up to 700 kHz).

3F35

High frequency material (up to 1 MHz). Very low losses, around 500 kHz.

3F4

High frequency material (up to 2 MHz). Specially recommended for resonant supplies.

3F45

High frequency material (up to 2 MHz). Specially recommended for resonant supplies.

3F5

High frequency material (up to 4 MHz). Specially recommended for resonant supplies.

4F1

High frequency material (up to 10 MHz). Specially recommended for resonant supplies.

Design Example 1

Series-series Compensated IPT Converter

Compensation Design:

Frequency & compensation capacitors

With efficiency consideration, the operating frequency may be chosen as 200 kHz.

$$f_o = \frac{1}{2\pi\sqrt{L_{L1}C_p}} = \frac{1}{2\pi\sqrt{L_{L2}C_s}} = 200 \text{ kHz}$$

Based on the leakage data for min gap (10 mm), we have

$$C_p = 28.6 \text{ nF}; C_s = 32.5 \text{ nF}$$

Main Parameters:

COMPONENTS	TYPES
Inverter MOS Switches	FB3307
Rectifier	B40250TG
Compensation Capacitor C_p	28.2nF
Compensation Capacitor C_s	33nF
Transformer Core	Ferrite 3F3, Planar E-Core 64/10/50 $N_p = 19, N_s = 17$

Design Example 1

Series-series Compensated IPT Converter

CONTROL STRATEGY BY FREQUENCY CHANGE

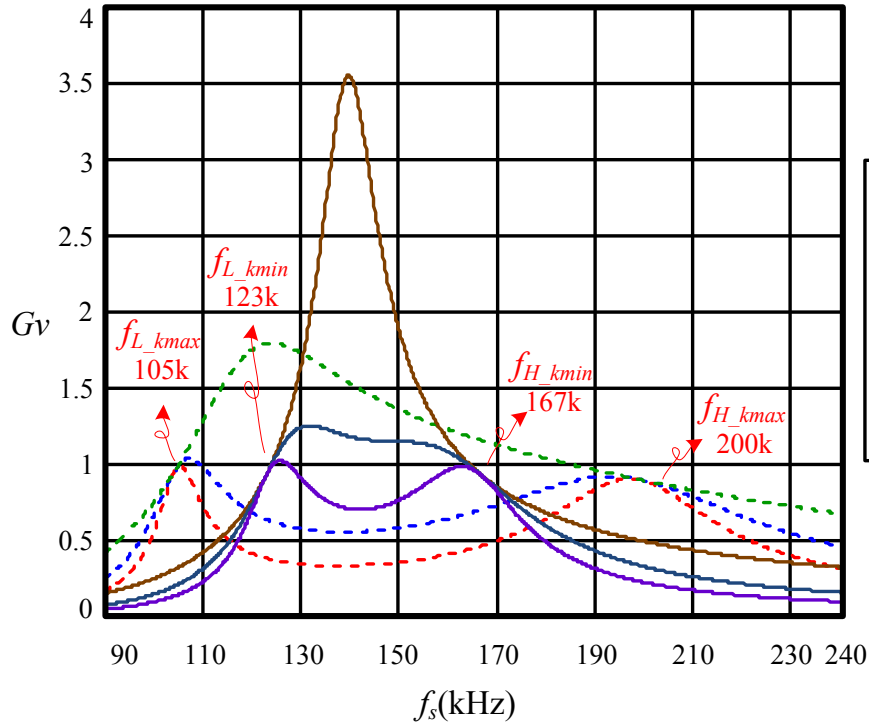

Voltage Gain Calculation

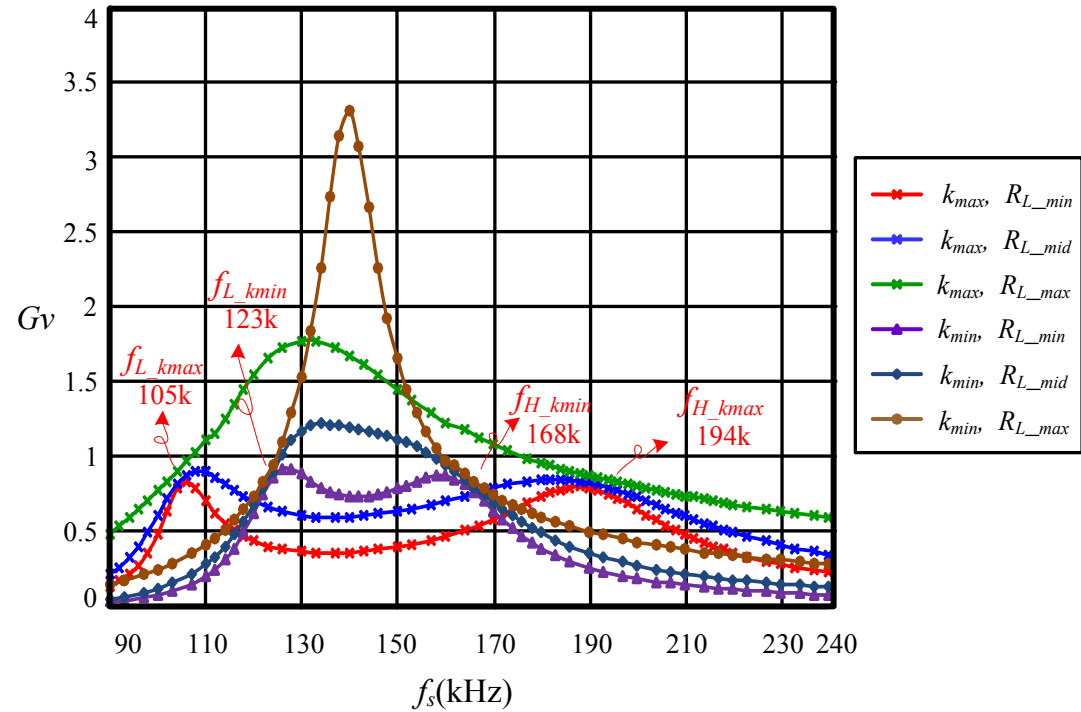

Measured Voltage Gain

Design Example 1

Series-series Compensated IPT Converter

Self oscillating control

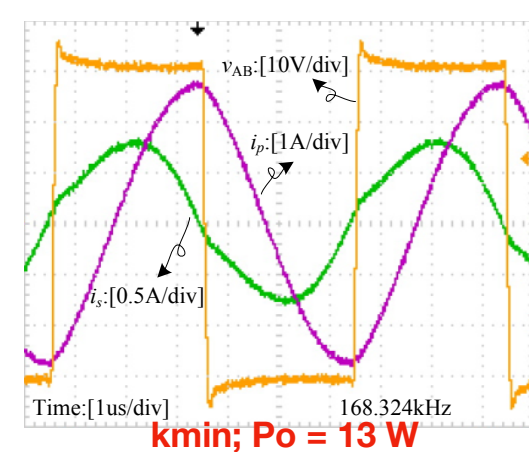
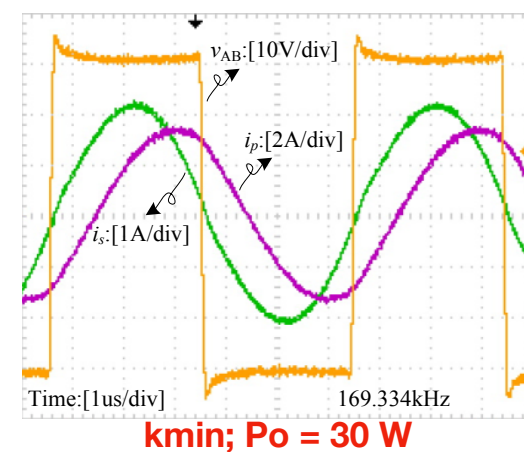
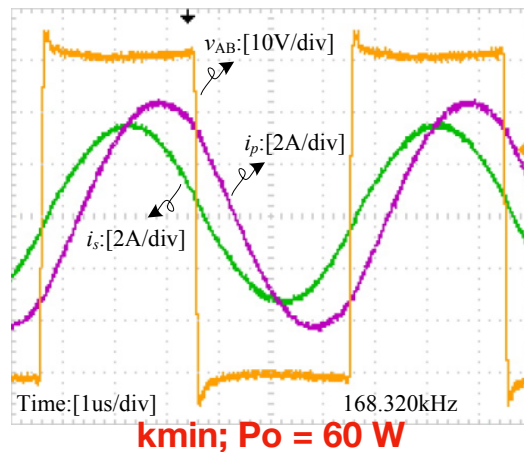
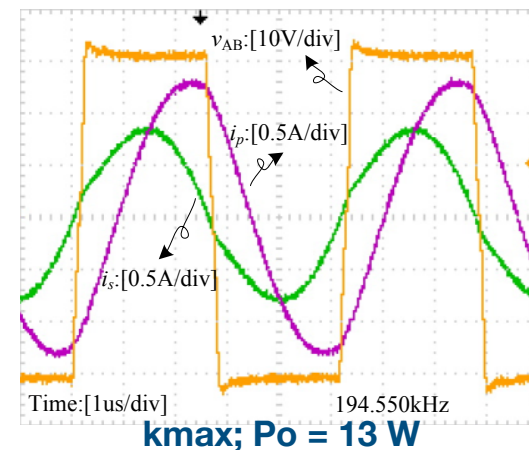
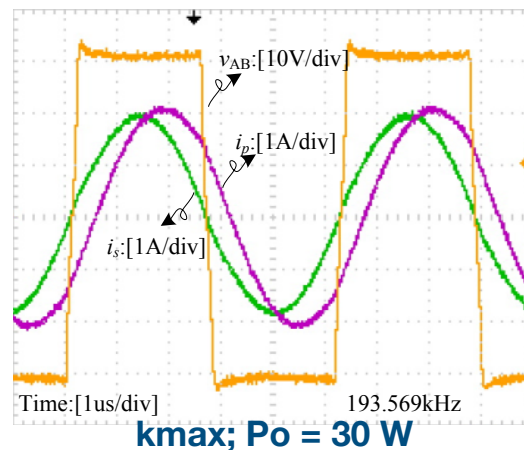
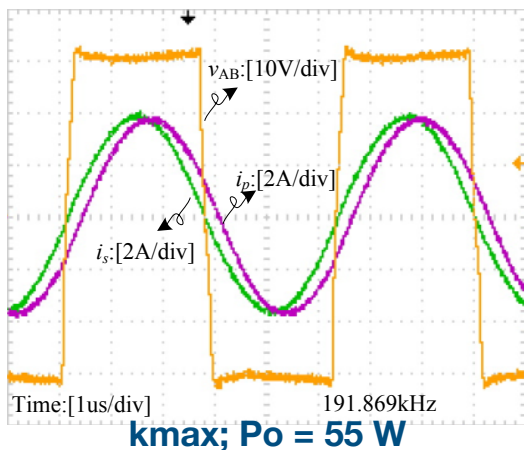

Design Example 1

Series-series Compensated IPT Converter

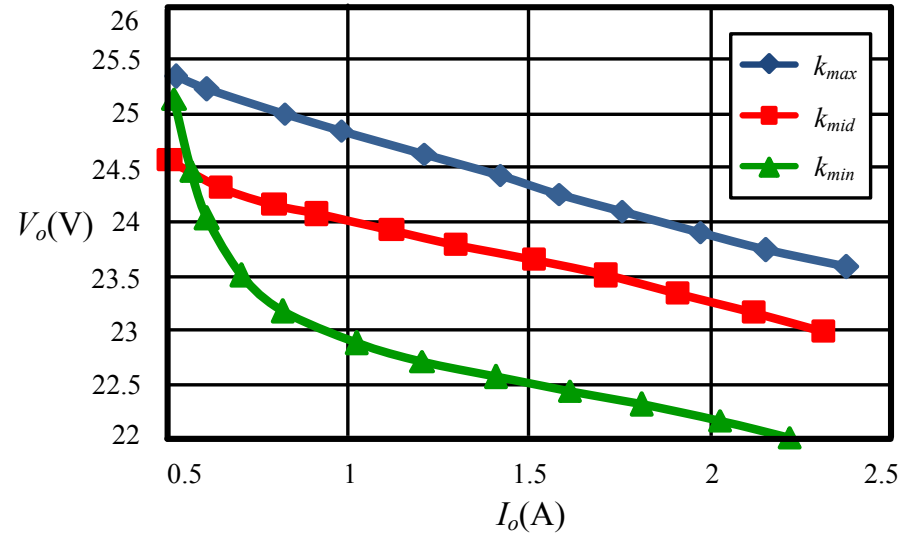

Output voltage

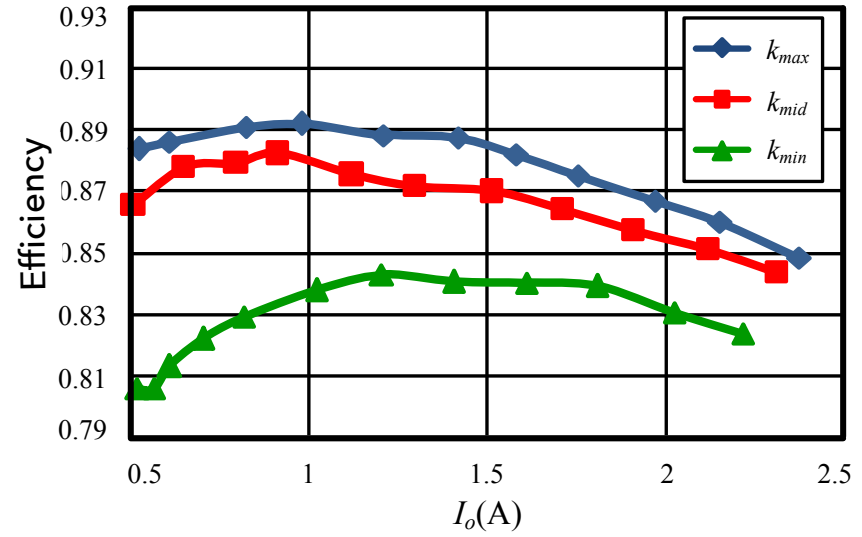

Efficiency

Design Example 2

Series-'series-parallel' Compensated IPT Converter

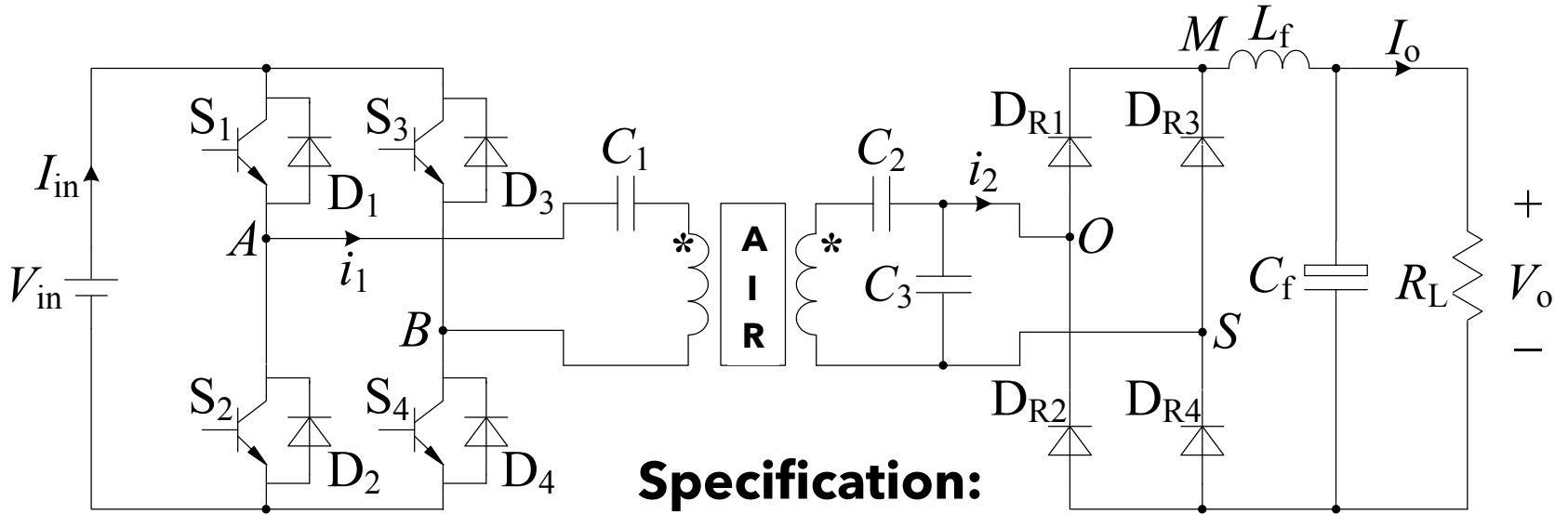

Specification:

DC Input: 528 V

DC Output: 400 V

Output Power: 1500 W

Gap: 10 ~ 20 mm

Design Example 2

Series-'series-parallel' Compensated IPT Converter

Extended planar transformer

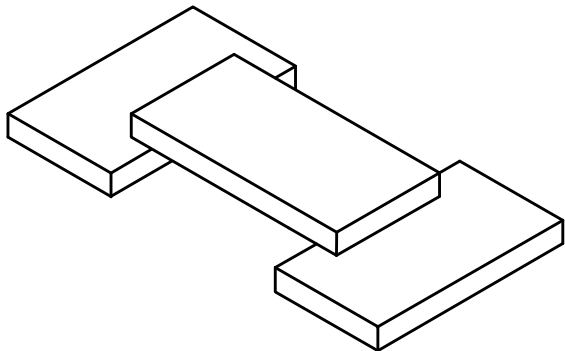

Increased area under perfect alignment.
Reduced fringe leakage fluxes.
Improved coupling.

Planar distributed windings

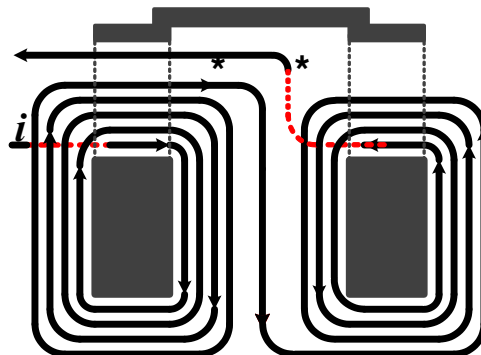

Reduced primary direct magnetic path
Improved coupling.
Reduced volume.

Design Example 2

Series-'series-parallel' Compensated IPT Converter

Design calculation:

Voltage Gain

$$G_v = \frac{8n}{\pi^2} = \frac{400}{528} = 0.7575$$

Turns ratio: $n = 0.935$.

Considering primary voltage resistive drop and frequency variation, take $n = 1$.

Also, $V_P = V_{AB} - V_{C1}$

Assuming I_P and V_{AB} are in phase, we apply the Faraday law:

$$u = N \frac{d\phi}{dt} \quad u = V_P$$

Hence,

$$u dt = N d\phi = NS dB \Rightarrow \int_0^t u \cdot dt = NS \int_{B(0)}^{B(t)} dB$$

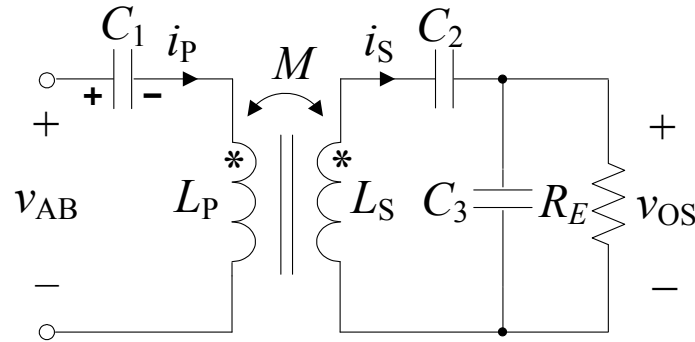

As long as V_{AB} is larger than the peak of V_{C1} , we can integrate over half cycle to get

$$B_m = \frac{V_{in}}{4fNS}$$

Thus, max flux density B_m is proportional to input voltage.

If max $B_m = 60$ mT, $S = 1778$ mm², $f = 40$ kHz, then we get

$$N = 30.9 \text{ (primary turns)}$$

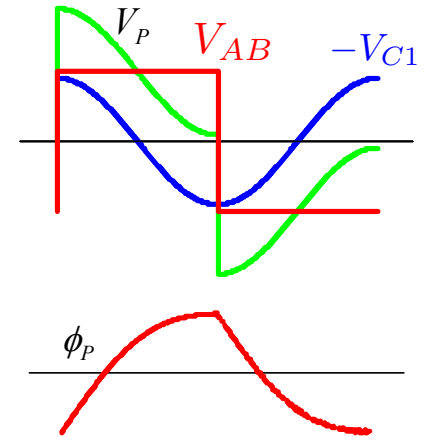

NOTE

$V_P = DC$ (input voltage) + cosine (cap voltage). This voltage is the primary terminal voltage that gives the flux density B_m . Integrating cosine over half cycle is 0.

Design Example 2

Series-'series-parallel' Compensated IPT Converter

Parameter Determination

Assembled core PLT 64 3C96 $N_p = 28$, litz wire φ 0.2mm x 145 $N_s = 28$, litz wire φ 0.1mm x 500 Weight: 13.6 kg (primary + secondary)		
GAP	k	Inductances
10 cm	$k_{\max} = 0.475$	$L_{L1} = 324.967$ mH, $L_{L2} = 362.56$ mH, $L_M = 310.948$ mH
12 cm	$k_{\text{mid}} = 0.434$	$L_{L1} = 347.03$ mH, $L_{L2} = 379.265$ mH, $L_M = 277.815$ mH
20 cm	$k_{\min} = 0.231$	$L_{L1} = 435.275$ mH, $L_{L2} = 462.95$ mH, $L_M = 134.85$ mH

Design Example 2

Series-'series-parallel' Compensated IPT Converter

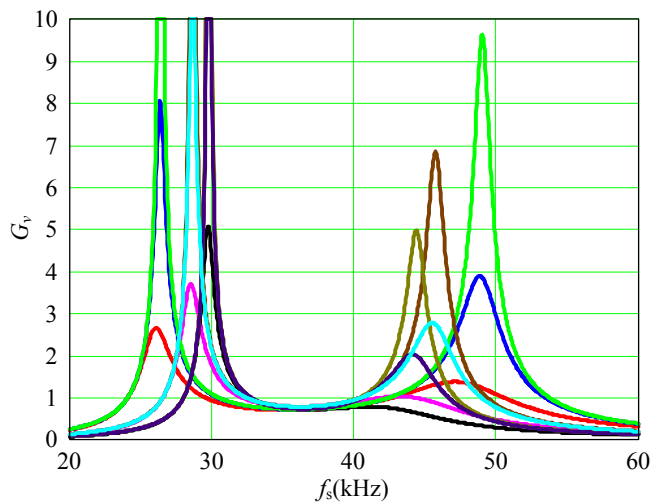

Full Compensation at 10 mm

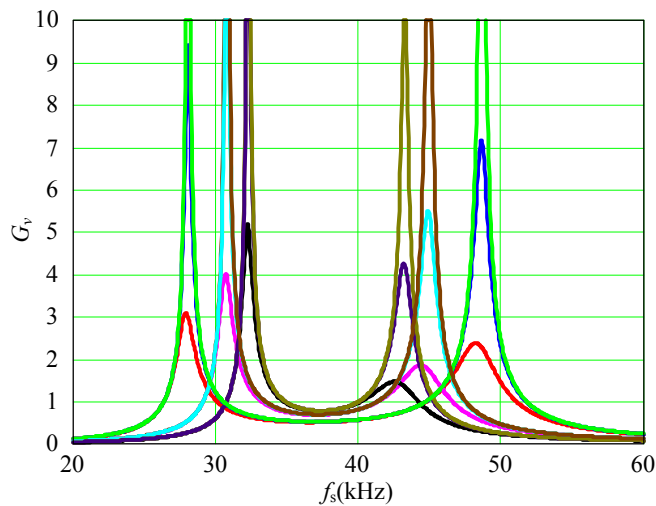

Full Compensation at 15 mm

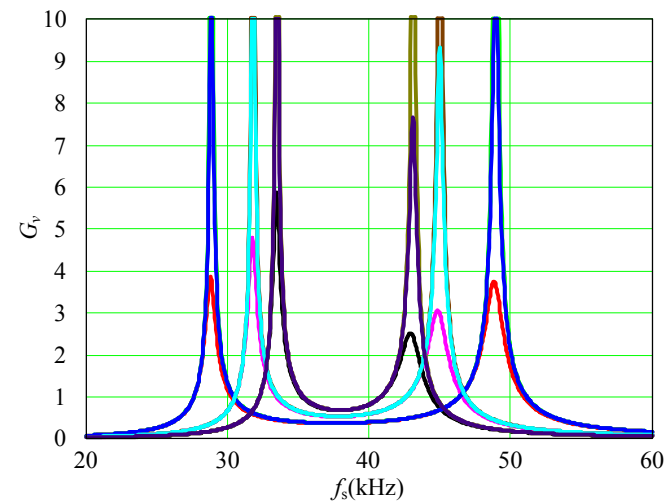

Full Compensation at 20 mm

$$\omega_r = \frac{1}{\sqrt{L_{L1}C_1}} = \frac{1}{\sqrt{L_{L2}C_2}} = \frac{1}{\sqrt{n^2 L_M C_3}}$$

$$C1 = 48.717 \text{ nF}$$

$$C2 = 43.665 \text{ nF}$$

$$C3 = 50.914 \text{ nF}$$

Design Example 2

Series-'series-parallel' Compensated IPT Converter

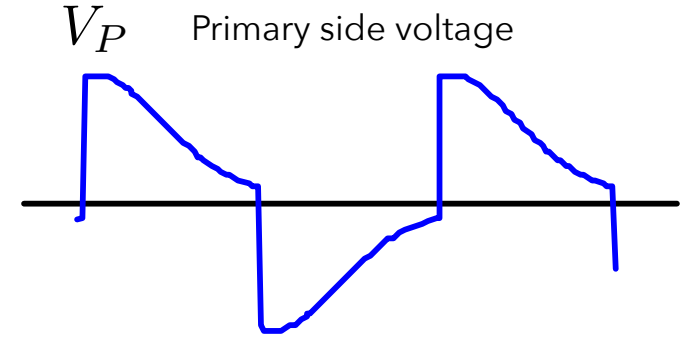

Secondary side voltage

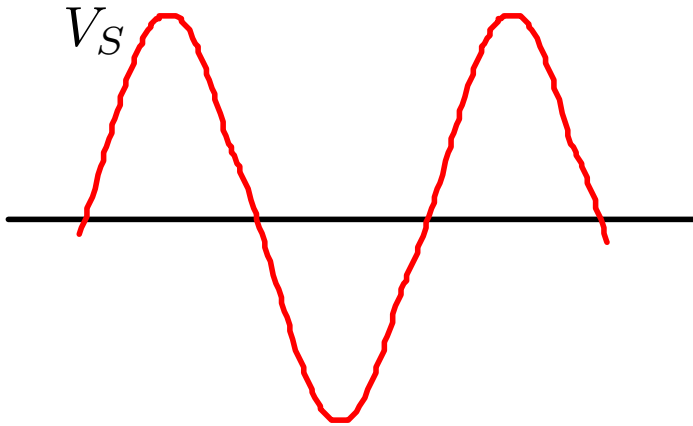

$$u dt = N d\phi = NS dB \Rightarrow \int_0^t u \cdot dt = NS \int_{B(0)}^{B(t)} dB$$

Max flux density can be found by applying V_P (which is the sum of a DC (input voltage) and a cosine (cap voltage)) as the EMF u at the primary terminals.

$$\text{Peak } B_m = 70 \text{ mT}$$

Secondary side V_S is a sine wave. Integrating over half a cycle gives

$$\text{Peak } B_m = 114.26 \text{ mT}$$

Design Example 2

Series-'series-parallel' Compensated IPT Converter

Inverter Design:

Taking a less perfect scenario of input angle 20° , and assuming an efficiency of 90%, we get the primary current as

$$I_P = \frac{P_o}{\eta V_{AB} \cos \theta} = 3.36 \text{ A}$$

So, the peak primary current is $I_P \sqrt{2} = 4.75 \text{ A}$

Use MOSFET SPW47N60CFD - 600 V, 40 A.

Rectifier Design:

Full load output current = $I_o = P_o/V_o = 3.75 \text{ A}$

Diode rms current = $I_D(\text{rms}) = 2.65 \text{ A}$

Diode average forward current = $2.65 / 1.57 = 1.69 \text{ A}$

Parallel compensation cap peak voltage = $1.8 V_o = 720 \text{ V}$

Use diode DSEP 30 - 12A, 1200 V, 30 A

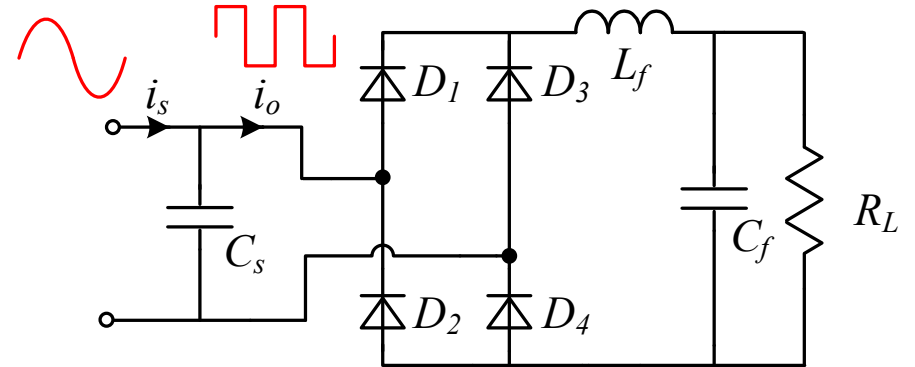

Design Example 2

Series-'series-parallel' Compensated IPT Converter

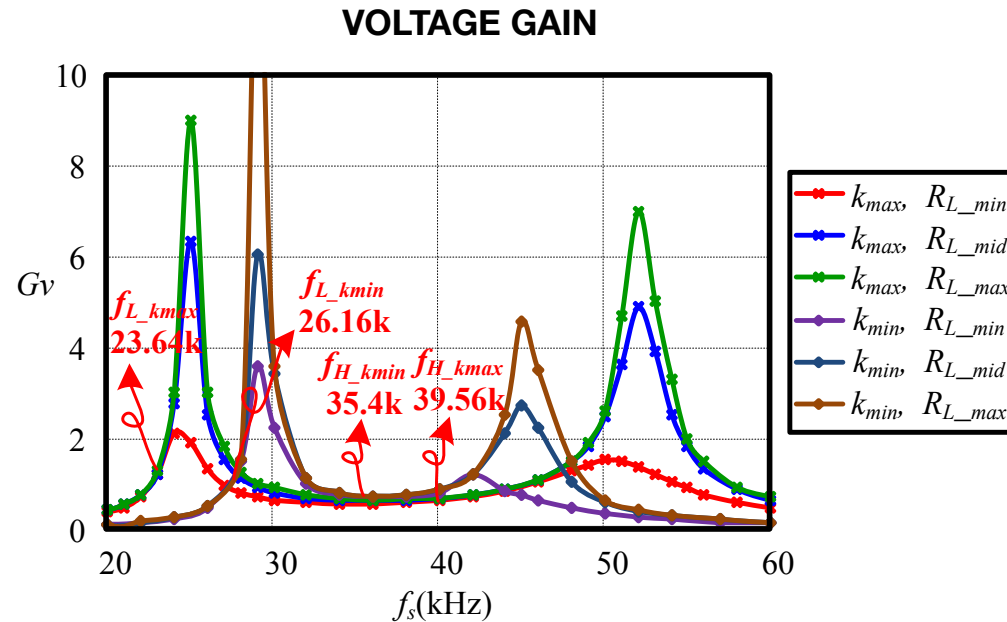

At frequency 39.22 kHz, the circuit gives load independent voltage gain or constant output.

Design Example 2

Series-'series-parallel' Compensated IPT Converter

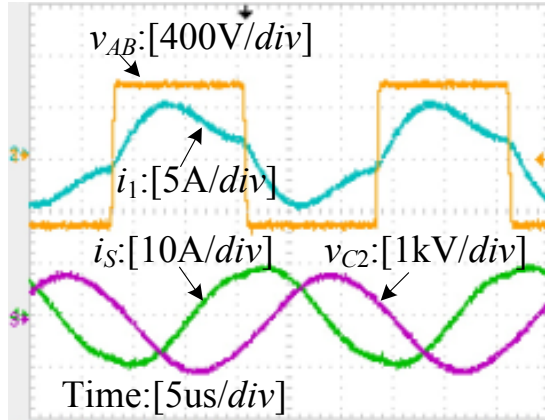

Gap 10 mm, full load

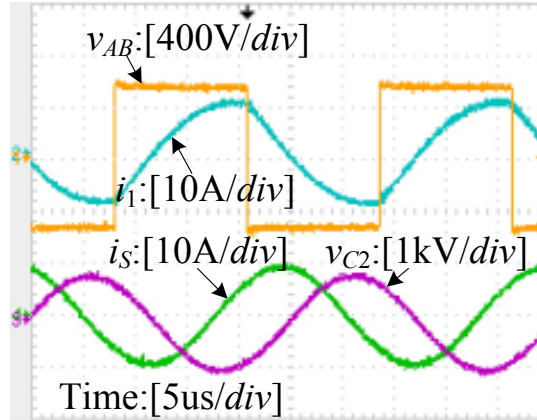

Gap 20 mm, full load

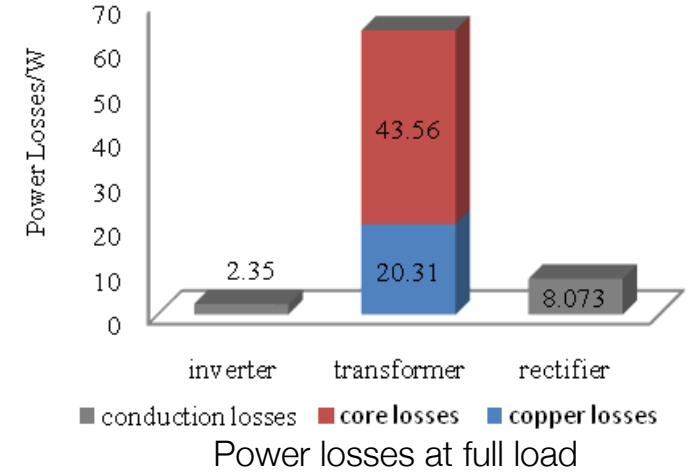

Operating frequency 39.22 kHz

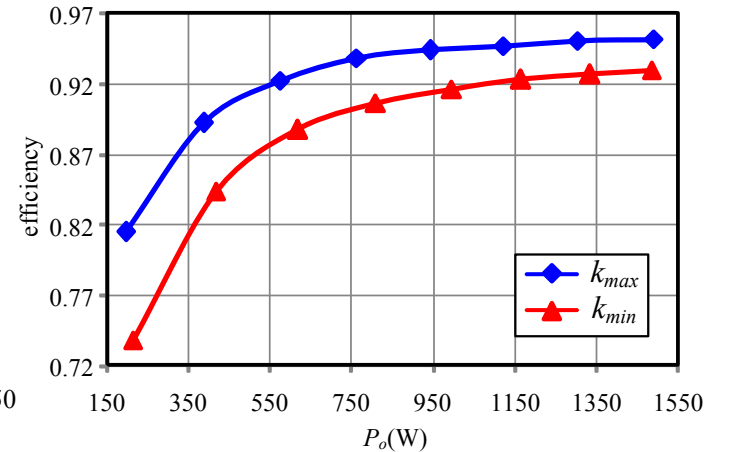
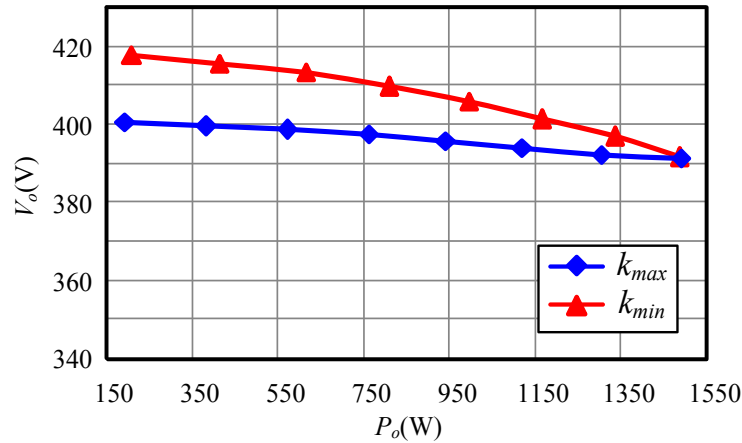

Safety Standards



WTO
EN62233

ICNIRP, "Guideline for Limiting exposure to time-varying electric, magnetic, and electromagnetic fields," 1998.

ARPANSA, "Maximum Exposure Levels to Radiofrequency Fields - 3 kHz to 300 GHz," 2002.

Range of Freq.	Limit values
1Hz~10MHz	Current density (Influence on nervous system)
100kHz~10MHz	Current density & SAR
100kHz~10GHz	SAR-Specific Absorption Rate (Fever of body)
10GHz~30GHz	Power density

Safety Standards

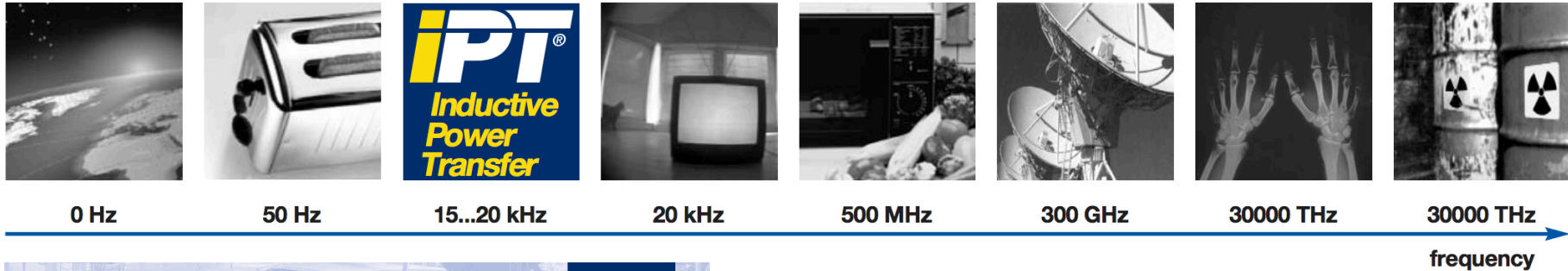

Evidence that IPT® does not present a health hazard

The IPT® system of Wampfler AG permits the contactless transmission of electrical energy by means of alternating magnetic fields. In public discussion, in the media, electromagnetic fields are ascribed an effect that is hazardous to health. At the same time, the term

"electromagnetic pollution" is often used for the large number of electromagnetic fields to which we are exposed each day. There is also great uncertainty because these fields are not accessible to the human senses and evidence of them can only be provided by means of

measurements. However, in order to assess any possible hazard for humans or animals by IPT® the resultant effect must be viewed in a more considered way. First of all some basic characteristics of electromagnetic fields need to be explained.

Magnetic induction [μT] in the vicinity of the IPT track for 125 A track current and a track conductor spacing of 100 mm. The points marked with **x** are the measurement positions.

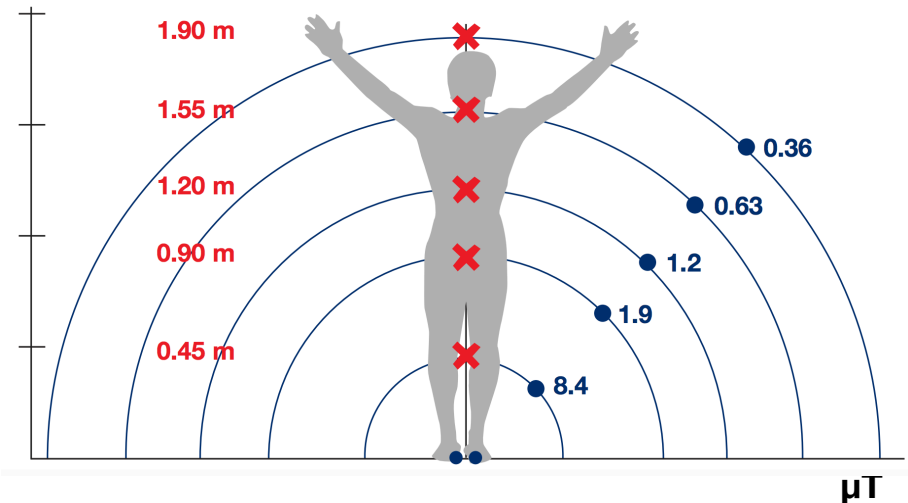

Max Tolerable Field Strength

Frequency range	E-field strength (V m ⁻¹)	H-field strength (A m ⁻¹)	B-field (μT)	Equivalent plane wave power density S_{eq} (W m ⁻²)
up to 1 Hz	—	3.2×10^4	4×10^4	—
1–8 Hz	10,000	$3.2 \times 10^4/f^2$	$4 \times 10^4/f^2$	—
8–25 Hz	10,000	$4,000/f$	$5,000/f$	—
0.025–0.8 kHz	$250/f$	$4/f$	$5/f$	—
0.8–3 kHz	$250/f$	5	6.25	—
3–150 kHz	87	5	6.25	—
0.15–1 MHz	87	$0.73/f$	$0.92/f$	—
1–10 MHz	$87/f^{1/2}$	$0.73/f$	$0.92/f$	—
10–400 MHz	28	0.073	0.092	2
400–2,000 MHz	$1.375f^{1/2}$	$0.0037f^{1/2}$	$0.0046f^{1/2}$	$f/200$
2–300 GHz	61	0.16	0.20	10

ICNIRP, "Guideline for Limiting exposure to time-varying electric, magnetic, and electromagnetic fields," 1998.

ARPANSA, "Maximum Exposure Levels to Radiofrequency Fields - 3 kHz to 300 GHz," 2002.

ICNIRP Limits

- General public:
 - Body average RMS flux density less than 27 μT in the frequency range of 3 kHz to 10 MHz.
 - Electric field limits is 83 V/m.
- Occupational exposure:
 - Magnetic flux density less than 100 μT .
 - E field exposure is 170 V/m
- Car chassis has shielding effect to magnetic field. Thus, the magnetic field inside a car is far below ICNIRP limits.

IEEE Limits

IEEE International Committee on Electromagnetic Safety.

IEEE Std. C95.1-2005

- The maximum permissible exposure of head and torso is 205 μT for general public, and 615 μT for occupation.
- The maximum permissible exposure for the limbs is even higher, which is 1130 μT for both the general public and occupation.

Field Strengths at Worst Position Near EV Charging

Human Model at the worst radiation point during slow EV charging.

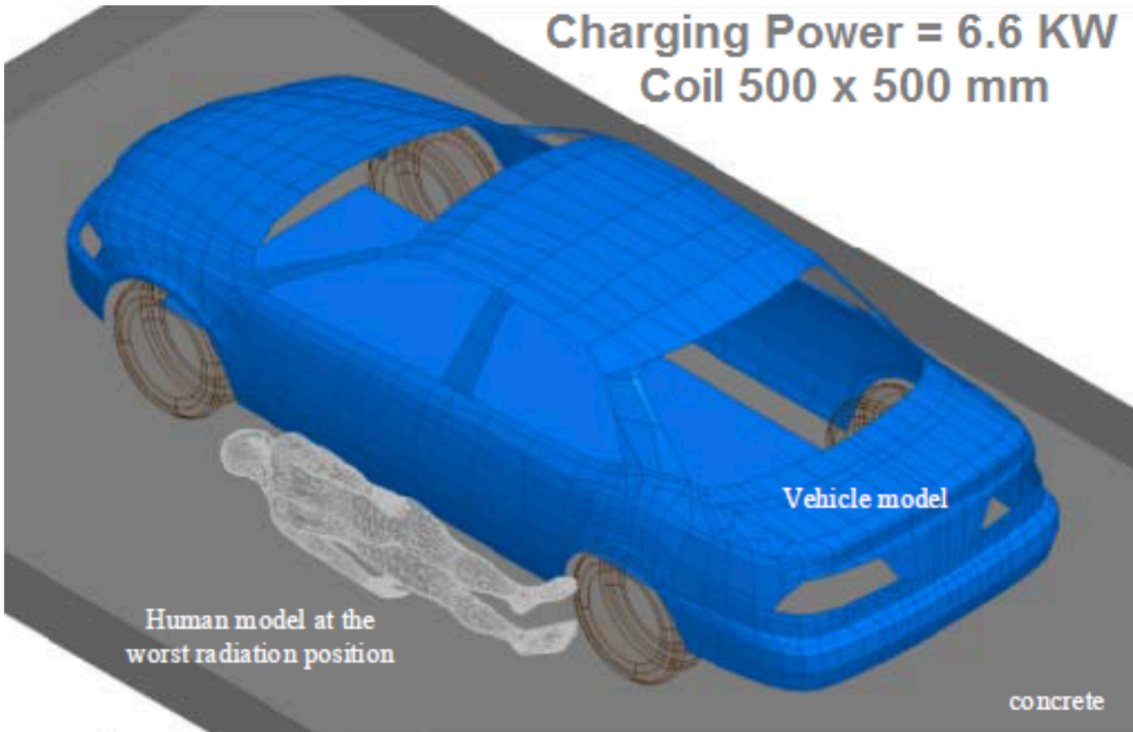

HUMAN MODEL

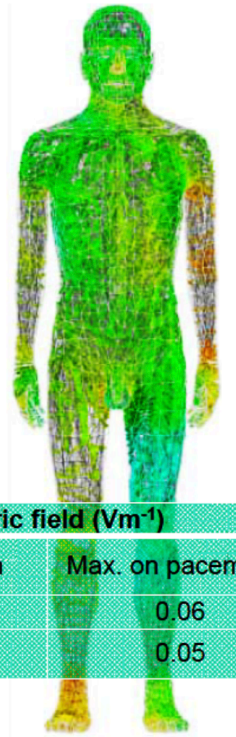
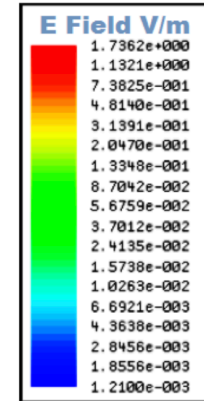
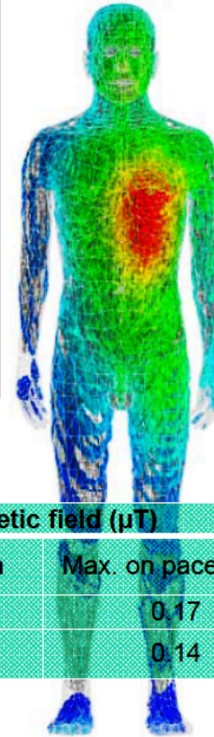
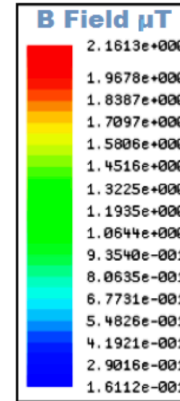

Magnetic field (μT)		Electric field (V/m)	
Max. on human	Max. on pacemaker	Max. on human	Max. on pacemaker
0.25	0.17	0.84	0.06
0.20	0.14	0.62	0.05

Sources: University of Michigan-Dearborn

Conclusions

- Power supply systems will see increasing use of wireless power transfer for convenience, safety, and standardized product development.
- EV charging will be an important market.
- Efficiency optimization, standardization, and tolerance of misalignment are the key technical challenges.
- Control methods will improve as the characteristics of various compensation configurations are better understood.
- More research needed:
 - Transformer optimization and physical design
 - Circuit design for higher order compensation to achieve more design flexibility and functionalities.
- IPT systems are generally very safe for human use.

FUTURE WORK

- OPTIMIZATION
 - HIGHER ORDER COMPENSATION
- STANDARD
 - DIRECT APPLICATION (SAVE A STAGE)
- CONTROL
 - DESIGN-BASED, ELIMINATING PERTURB&OBSERVE
- MORE TRANSFORMER STUDIES (EMPIRICAL AND ANALYTICAL)